

Product
Catalogue

ROOFING
SERIES

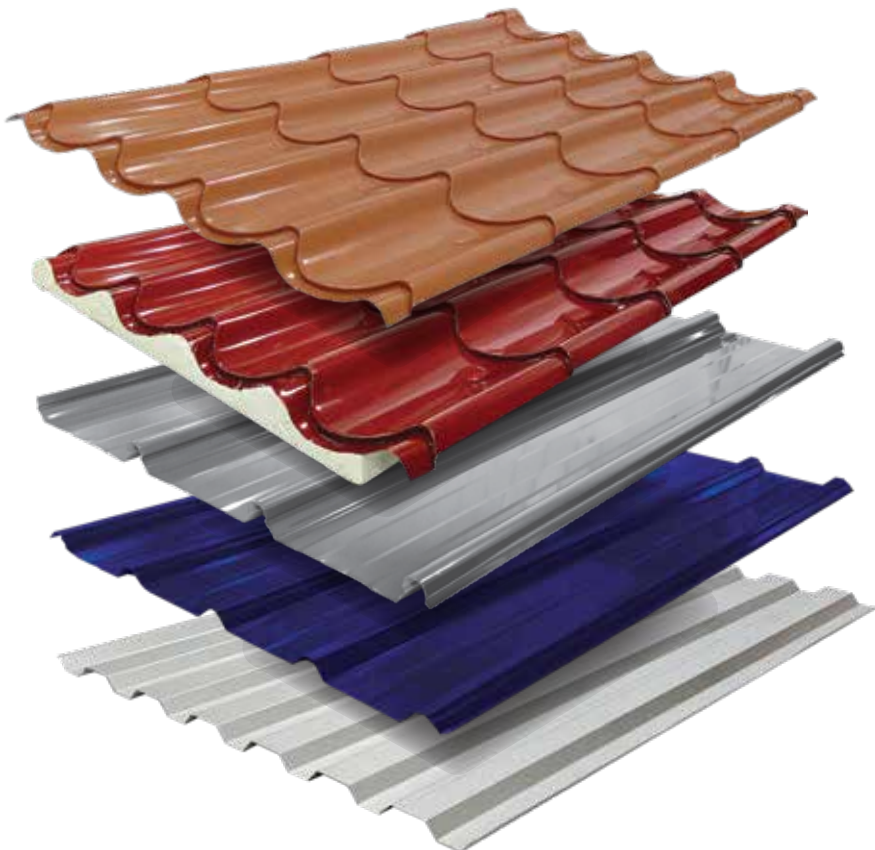

CONTENT

3	ABOUT THUNG HING
4 - 7	TH PU FOAM TH PU FOAM 762 TH PU FOAM ULROLL BOND TH PU FOAM SUPERIOR RIB 35 TH PU FOAM RIB 30 TH PU FOAM CRIMP CURVE
8	TH DECK 762
9	TH ULROLL BOND
10	TH SUPERIOR RIB 35
11	TH RIB 30
12 - 13	TH MEGA RIB 50
14	TH CRIMP CURVE & HALF ROUND
15 - 17	TH CLIP LOCK OPTIMA 730
18 - 19	TH® CLIP LOCK 710
20 - 21	TH® CLIP 760
22 - 23	TH® LOCKSEAM 75
24	TH VERTICAL STANDING SEAM
25	TH R505 STANDING SEAM
26 - 29	TH SPANDEX
30	CAPPING & FLASHING
31	COLOUR SELECTION CHART



DELIVERING EXCELLENCE, BUILDING SOLUTIONS.



HQ Selangor



Kedah



Kelantan



Terengganu



Johor



Sabah

Founded in 1983, Thung Hing established itself as a fore runner of high quality steel products manufacturing, particularly building materials for the construction industry. Our ISO 9001 certified factories in Rawang Industrial area, Malaysia, manufactures products to meet the demands of our clients from all over the world.

From the humble beginnings of fixing residential roof gutters 20 years ago, passion and hard work have equipped Mr. Lee with skills and expertise in the metal works trade, not to mention earning him a steady customer base who seek the craftsmanship and superior quality that became synonymous with the Thung Hing name. Having grown the company industrially and strategically to date, Mr Lee's ambition and innovations continue to drive new product categories, value-added services and international quality assurance. This commitment to every customer will continue to write the Thung Hing legacy.

Our Journey

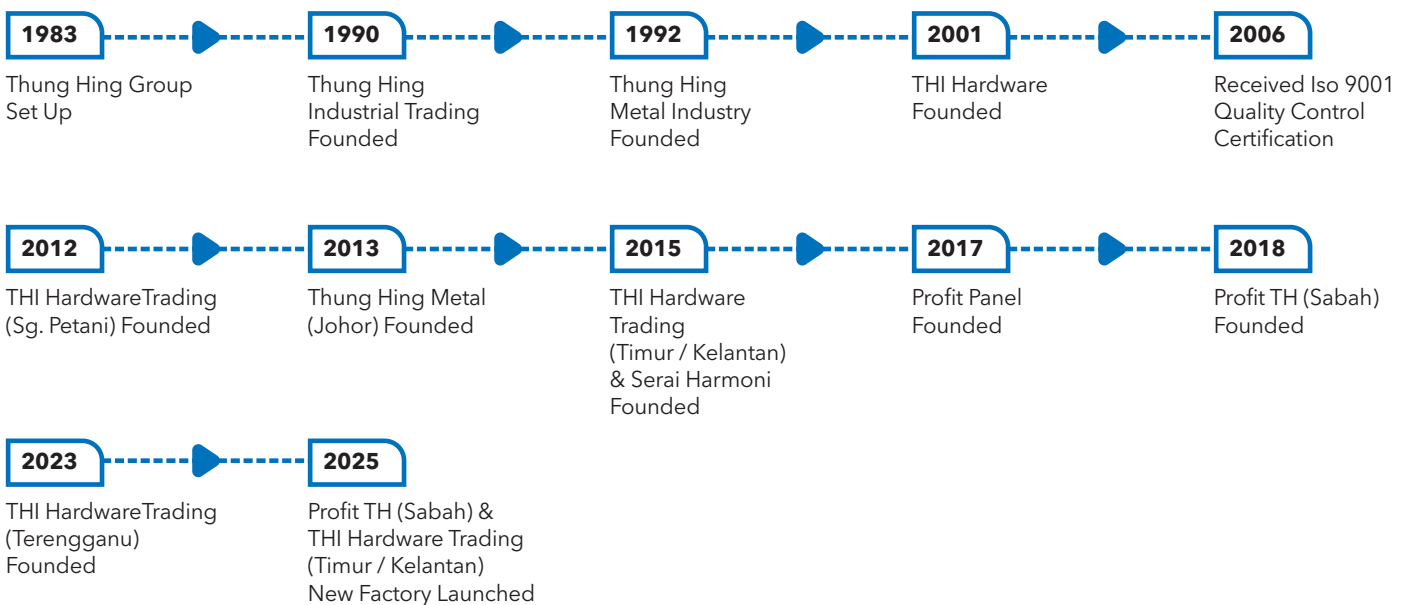

TH PU FOAM

TH PU FOAM series is complete insulated roofing panels with outstanding thermal efficiency. It is manufactured by bonding CFC-free Rigid Polyurethane (PU) foam between exterior profiled metal roofing sheets and interior fire retardant PVC lamination paper / metal line / aluminium foil. These insulated metal roofing panels are distinguished by a combination of high insulation characteristics and light weight. The interior lamination is glossy and textured create an aesthetically attractive appearance.

PU Foam Metal

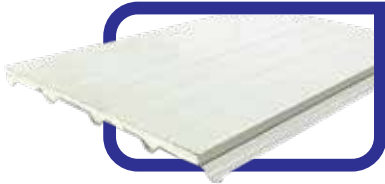

PU Foam Aluminium Foil

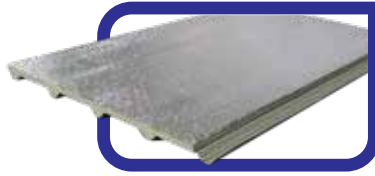

PU Foam PVC Paper

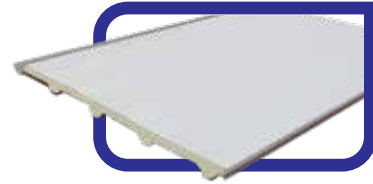

TH PU FOAM 762



PU Foam / PU Foam Aluminium Foil

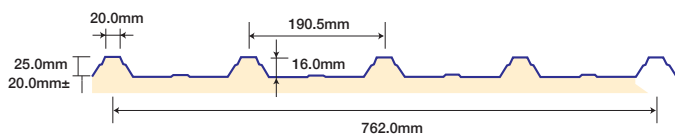

PU Foam Metal

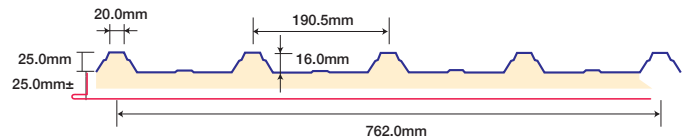

TH PU FOAM ULROLL BOND



PU Foam / PU Foam Aluminium Foil

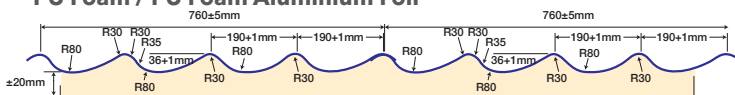

PU Foam Metal

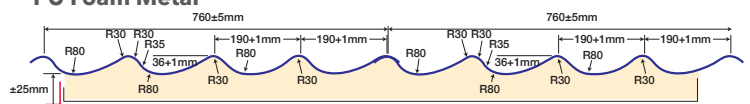

TH PU FOAM SUPERIOR RIB 35

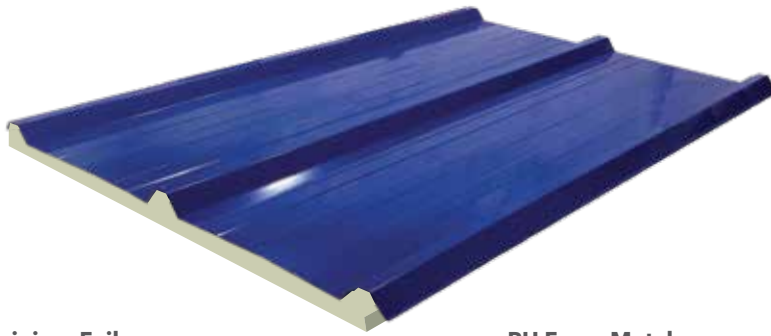

PU Foam / PU Foam Aluminium Foil

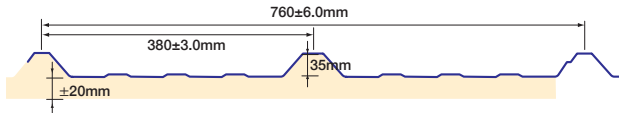

PU Foam Metal

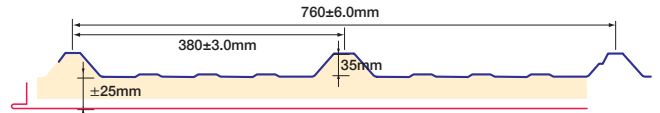

TH PU FOAM RIB 30

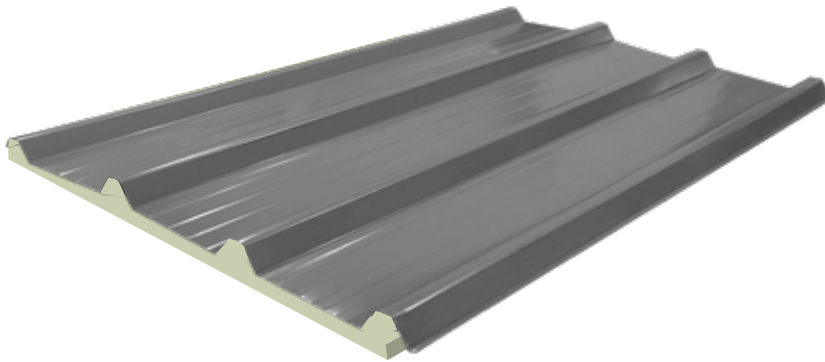

PU Foam / PU Foam Aluminium Foil

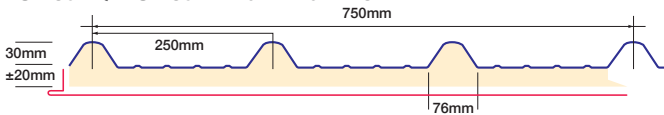

PU Foam Metal

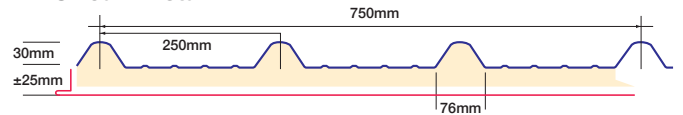

TH PU FOAM CRIMP CURVE

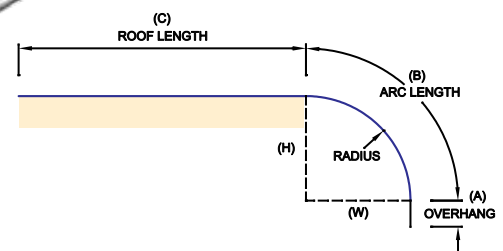

SPECIFICATIONS

WIND CAPACITY LOAD SPAN TABLE

Thickness TCT (mm)	Uniformly Distributed Load (kN/m ²) Span L (m)							
	0.6	0.9	1.2	1.5	1.8	2.1	2.4	2.7
0.42	18.36	5.44	3.06	1.57	0.91	0.57	0.38	0.27
0.45	19.89	5.89	3.31	1.70	0.98	0.62	0.41	0.29
0.48	21.42	6.35	3.57	1.83	1.06	0.67	0.45	0.31
0.53	23.96	7.10	3.99	2.04	1.18	0.75	0.50	0.35
0.55	24.97	7.40	4.16	2.13	1.23	0.78	0.52	0.37

MAXIMUM RECOMMENDED SUPPORT SPACING

Thickness TCT (mm)	Roof		Wall		Overhang (mm)
	Internal Span (mm)	End Span (mm)	Internal Span (mm)	End Span (mm)	
0.42	1800	1550	2050	1850	150
0.45	1900	1650	2200	2000	150
0.48	1950	1700	2250	2050	150
0.53	2050	1800	2350	2150	200
0.55	2050	1800	2350	2150	200

Disclaimer : The information on the materials presented herein is provided for informational purposes only. Thung Hing shall not be liable for any loss or damage whatsoever arising from, but not limited to the usage of the information provided. Any omission, error, typographical errors and technical inaccuracies relating to the information may be changed or updated without notice.

Other thickness are subject upon stock availability and time delivery
 0.48 TCT available for Clean Colorbond only. 0.47 TCT available for Prima Maju, Primero, Zinalume & PPGI

Side Lap

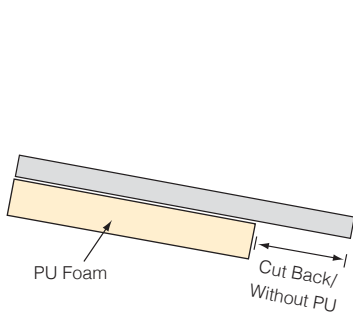

Panel End Lap

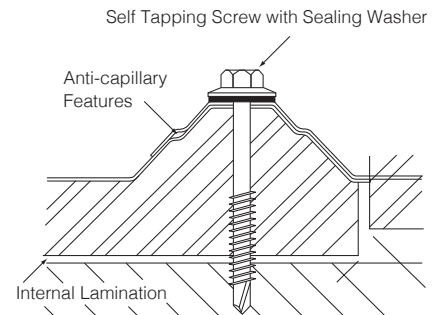
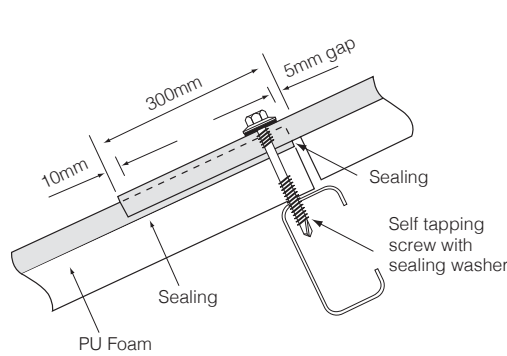

TH PU FOAM series provides excellent heat resistance, good sound absorption, mechanical and dimensional stability of roof assembly. The overall result is roofing system that maintain your buildings cool all day long with great saving on electricity.

TH PU FOAM eliminates unnecessary multiple construction processes of laying insulations and construction expenditures in term of labour usage, transportation, storage and purchasing costs. It contains water resistant materials which will not be damaged by rain water. It is also with smoke resistant as well. The interior lamination colour is white which enhance reflectivity, durability and require low maintenance.

THICKNESS FOR EQUIVALENT INSULATION PERFORMANCE OF COMMON BUILDING MATERIALS



AVAILABLE LENGTH

Custom cut length available according to order.

PRODUCT TOLERANCES

Length : ±10mm
 Width : ±5mm to ±6mm
 Thickness : ±0.02mm / per single metal sheet

WARRANTIES

THUNG HING provides warranties on an individual project basis.

PACKING

TH PU FOAM series insulated roofing is stacked face to face and back to back. The top and bottom are protected with timber and additional roofing sheets. The number of pieces in each pack depends on length. Quantities are reduced for longer roofing sheets.

The table below show as guide of packing:

Thickness TCT (mm)	Length (ft.)										
	10	12	14	16	18	20	22	24	26	28	30
0.42~0.55	28	28	28	28	28	28	24	24	24	24	24

PRODUCT DESCRIPTION

TH PU FOAM series made up of 3 layers of prepainted steel, rigid Polyurethane (PU) and the fire retardant PVC lamination paper / metal Line / aluminium foil. It is a complete insulation system built into a single product which can effectively reduce heat and noise

TH PU FOAM	Material	Thickness
PU Foam	PVC Paper	20mm +/-
PU Aluminium	Aluminium Foil	20mm +/-
PU Metal	Metal	25-50mm +/-

INSULATION PROPERTIES

Items	Specification		
Type of insulation	Bonded Rigid Polyurethane		
Thickness of Insulation	20±	25±	50±
Insulation Density	35-42 kg/m³		
Thermal Resistance (R)	1.18 m² K/W	1.47 m² K/W	2.94 m² K/W

TH DECK 762



SECTIONAL PROFILE

Dimension

RIB height : 25mm
 Effective cover : 762mm
 Minimum roof pitch : 3°

Tolerance

Thickness of material : ±0.03mm
 Effective width : ±3mm
 Finishing length : ±5mm

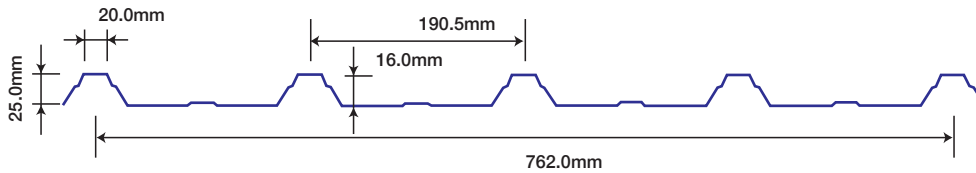

762 (Effective cover width)
 (All dimensions are in mm)

TECHNICAL DATA - AVAILABLE THICKNESS

Base Metal Thickness (mm)	Total Coated Thickness (mm)	Weight (kg/m ²)	Steel Grade	Min. Yield Strength (MPa)
0.35	0.40	3.46	AS1397	G550
0.42	0.48	4.20	AS1397	G550
0.48	0.53	4.76	AS1397	G550

Other thickness are subject upon stock availability and time delivery
 0.48 available for Clean Colorbond only. 0.47 available for Prima Maju, Primero, Zinalume & PPGI

RECOMMENDED MAXIMUM ROOF LENGTH (M)

Slope in Degree	3°			5°			7°		
	Rainfall (mm/h)								
150	50			60			80		
200	39			50			60		
250	30			40			48		
300	26			30			40		

RECOMMENDED MAXIMUM SPACING OF SUPPORT

Base Metal Thickness (mm)	Total Coated Thickness (mm)	ROOFS		WALLS	
		End Span (mm)	Internal Span (mm)	End Span (mm)	Internal Span (mm)
0.35	0.40	900	1000	1200	1500
0.42	0.48	1200	1500	1700	2000
0.48	0.53	1300	1700	2000	2300

TH ULROLL BOND



TH ULROLL BOND is available in custom lengths and thickness to suite site measurement.

TH ULROLL BOND - Panel Section

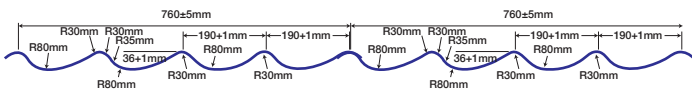

Typical TH ULROLL BOND Tilesheet

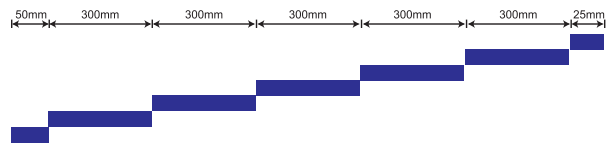

Roof Sheet Laying

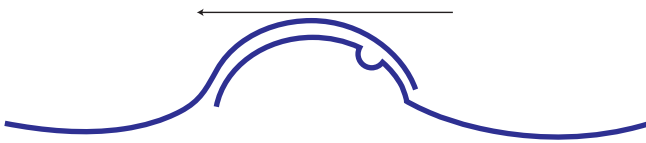

Roof Battens

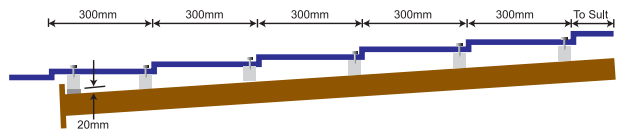

TH ULROLL BOND is designed to look like EURO clay tiles, with its attractive and efficient design, **TH ULROLL BOND**, the best replacement for conventional concrete or clay tiles. Reliable weatherproof system, it becomes ideal for all building's roof.

Thung Hing Metal is a reliable metal roofing products manufacturer. With sophisticated roll-forming machinery, Thung Hing Metal has already provides wide-range of metal roofing products for Malaysians.

STANDARD MATERIAL SPECIFICATIONS

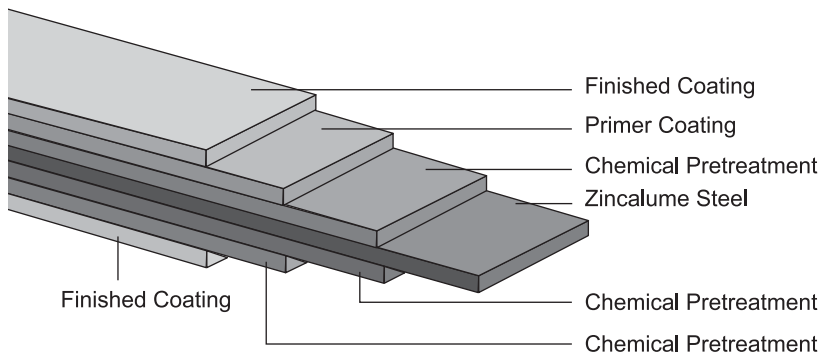

Gauge	B.M.T.	T.C.T.
26	0.42	0.47
27	0.35	0.40
28	0.30	0.35
30	0.25	0.30

TH SUPERIOR RIB 35



TH RIB 35 is a versatile roof and wall cladding featuring bold, trapezoidal ribs and three ribs and three subtle fluted which is ideal for commercial, residential and industrial building. It is made of high strength steel and despite its lightness, provide long length and excellent spanning capacity.

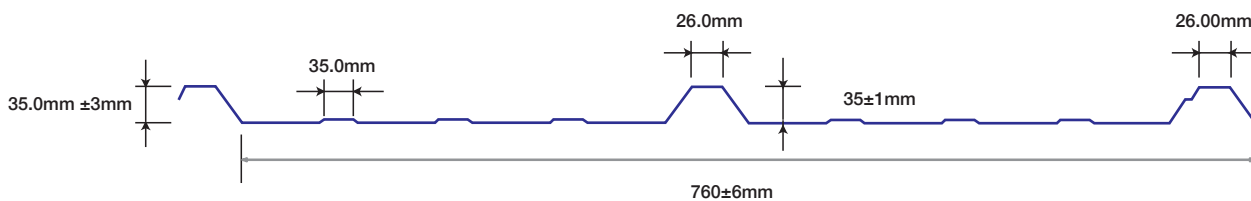

760±6 (Effective cover width) (All dimensions are in mm)

- Roll-forming long length high tensile metal decking with three fluted pans.
- Manufactured from high tensile steel substrate protected with corrosion inhibitive treatment.
- Roofing and walling profiles with material warranty up to 25 years (T&C).
- Effective cover width of 750mm and rib height of 35mm for TH RIB 35.
- For minimum roof pitch of 2°.
- High rib to ensure good spanning capability and excellent water-discharge capacity.
- Can be custom made lengths with options for on-site-forming.
- Widely used for commercial and industrial projects like shop offices, schools, multi-purpose halls, apartments, sprung curve roofs, etc.

TH RIB 30

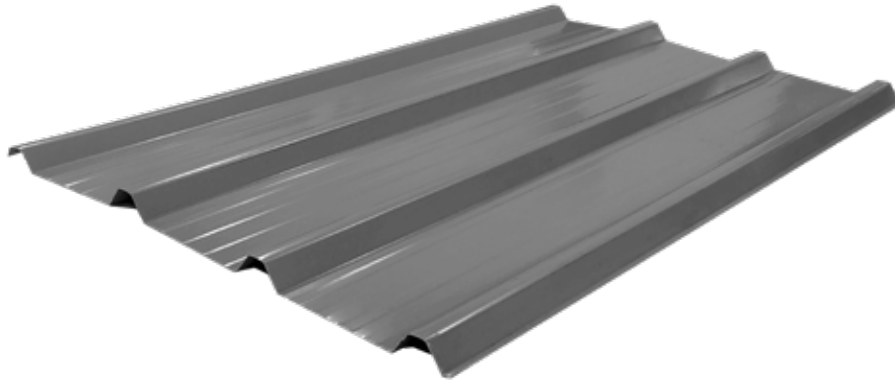

DIMENSION

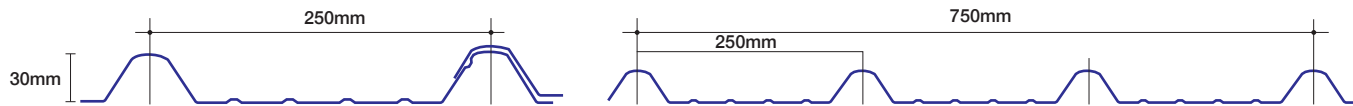

TH RIB 30	• Rib height : 30mm	• Effective cover : 750mm	• Minimum roof pitch : 2°
------------------	---------------------	---------------------------	---------------------------

SAMPLE OF SPECIFICATION

0.42mm BMT (thick) TH RIB 30 Hi-tensile Metal Roofing Sheets in pre-painted hot-dipped zinc-coated steel or pre-painted hot-dipped zinc-aluminium alloy-coated steel to be fixed with / without insulation, and come complete with necessary fitting and accessories. Details in accordance with manufacturer's instructions.

TECHNICAL SPECIFICATIONS

AVAILABLE THICKNESS

Base Metal Thickness (BMT) mm	Total Coated Thickness mm	* Weight per metre (kg/m)	* Weight per sq metre (kg/m ²)	* Coverage per ton (m ² /MT)	Steel Grade	Minimum Yield Strength (MPa)
0.35	0.40	2.73	3.65	3.78	ASTM A446-E	550
0.42	0.48	3.24	4.32	4.48	ASTM A446-E	550
0.48	0.53	3.67	4.89	5.07	ASTM A446-E	550

0.60mm BMT is available on request. Please refer to our technical department.
* Weight shown above is depending on material used.

Other thickness are subject upon stock availability and time delivery
0.48 available for Clean Colorbond only, 0.47 available for Prima Maju, Primero, Zinalume & PPGI

PRODUCT FEATURES

- Long spanning capacity
- Good rain water flow capacity
- Custom made lengths with options for on-site rilling
- Available in various thicknesses steel roofing & colours

Curvature	
• Nature Curve	: > 80mr Radius
• Crimp Curve	: > 600mr Radius
Tolerance	
• Thickness for Material	: ±0.03mm
• Effective Width	: ±3mm
• Rib Height	: ±1.5mm

- Roll-forming long length high tensile metal decking with three fluted pans
- Manufactured from high tensile steel substrate protected with corrosion inhibitive treatment
- Roofing and walling profiles with material warranty up to 25 Years (Terms & Conditions apply)
- Effective cover width of 750mm and rib height of 30mm for TH RIB 30
- For minimum roof pitch of 2°
- High rib to ensure good spanning capability and excellent water-discharge capacity
- Can be custom made lengths with option for on site-forming
- Widely used for commercial and industrial projects like shop offices, schools, multi-purpose halls, apartment and etc.

TH MEGA RIB 50



TH MEGA RIB 50 was designed specifically to provide a wide spanning capability and a distinctive appearance to provide better roof traffic. The large robust ribs and exceptional water carrying capacity of this profile make it ideal for large high performance roofs such as conventional mall, power station industrial or commercial building.

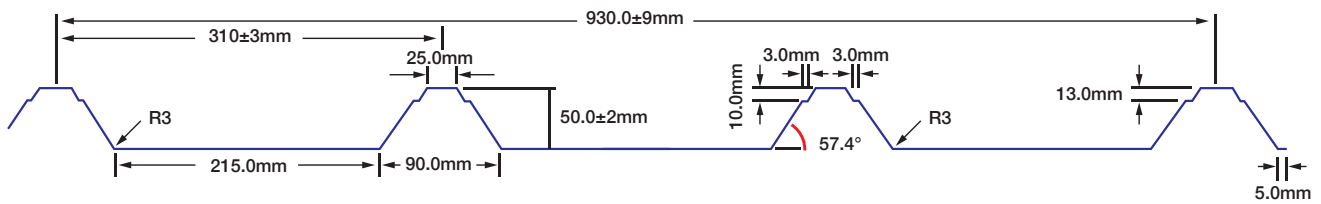

930±9 (Effective cover width) (All dimensions are in mm)

		Pressure KPa						
		Allowable span (m)						
mm		0.50	0.75	1.00	1.25	1.50	1.75	2.00
0.9mm	Single Spar	2.15	1.85	1.70	1.60	1.50	1.40	1.30
	2 continous spans	2.40	2.15	1.95	1.75	1.60	1.50	1.40
0.7mm	Single Spar	1.80	1.70	1.55	1.45	1.35	1.25	1.15
	2 continous spans	2.15	1.95	1.65	1.50	1.35	1.25	1.15
0.53mm	Single Spar	1.75	1.60	1.45	1.30	1.20	1.10	1.05
	2 continous spans	2.05	1.70	1.50	1.30	1.20	1.10	1.05

Aluminium design based on Eurocode deflection limit of L/240

Section Properties

Thickness mm (BMT)	Area mm ²	I mm ⁴	Y mm	Z mm ³
0.42	512	177506	35.90	4898
0.48	585	202865	36.0	5598
0.53	670	231974	36.10	6426
0.70	853	295496	36.16	8172
0.90	1097	380371	36.24	10496

Other thickness are subject upon stock availability and time delivery

0.48 available for Clean Colorbond only. 0.47 available for Prima Maju, Primero, Zinalume & PPGI

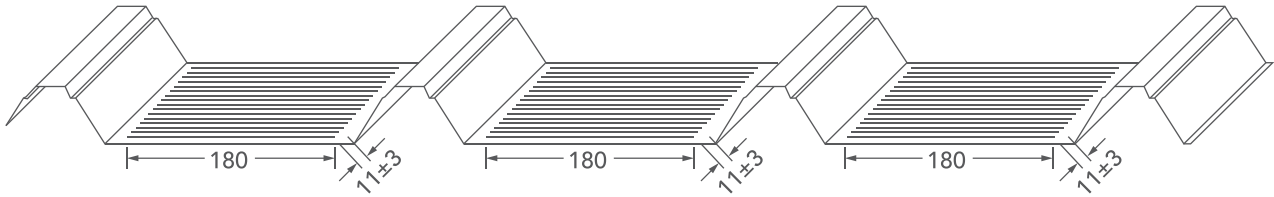

Max Eave Overhang Unsupported

Thickness mm (BMT)	mm
0.42	150
0.48	150
0.53	200
0.70	200
0.90	300

* minimum roof pitch is 1 degree based on 325mm/hr

Other thickness are subject upon stock availability and time delivery

0.48 available for Clean Colorbond only. 0.47 available for Prima Maju, Primero, Zinalume & PPGI

TH CRIMP CURVE & HALF ROUND

TH Crimp Curve and TH Half Round Metal Roofs are most suitable to be used in building porches, verandas and bus shelters. It allows flexibility in building designs. Builders are no longer confined to only flat, and angled roof options but can now incorporate concave curves to them. Besides adding beauty to the building, it is also cost effective, practical and easy to install, thus speeding up the construction process.



TH HALF ROUND PROFILE



TH CRIMP CURVE PROFILE

SECTIONAL PROFILE

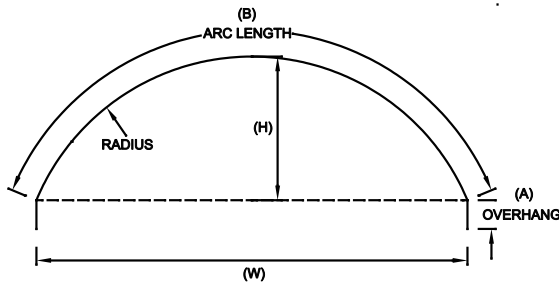

Minimum distance (h) : 650mm
Minimum distance (w) : 1300mm

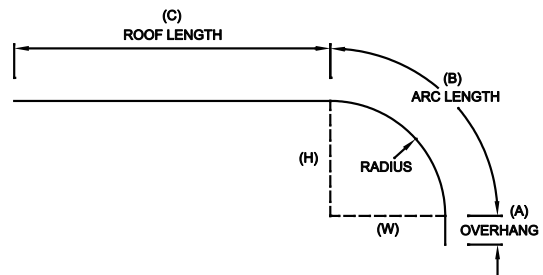

Minimum distance (a) : 305mm
Minimum distance (b) : 25mm
Standard distance (c) : 380mm

- High Tensile
- Anti Corrosive
- 25 Years warranty*
- Reduce cladding material required to cover a given area.
- Simplified and reduces work involved in installation of fascia capping.

TH CLIP LOCK OPTIMA 730

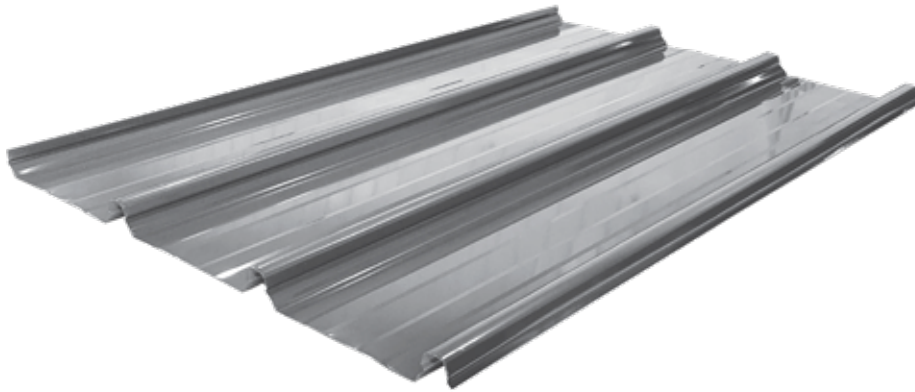

SECTIONAL PROFILE

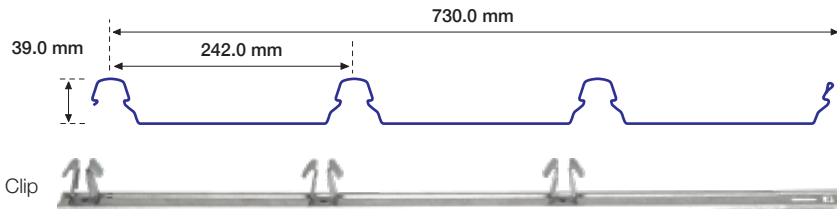

TH Clip Lock Optima 730 is a new generation of wide-cover concealed-fixed cladding. Made of high tensile 550 MPa yield strength, it spans wide, with better uplift performance than all available comparable profiles.

The profile is fixed on a specially designed clip, manufactured from a high tensile steel base and designed to withstand high wind pressure. This provides accuracy, economy and ease during the installation and makes it a superior lasting product design.

TH Clip Lock Optima 730 sheets have an effective cover width of 730mm with ribs of approximately 39mm in height spaced at 242mm between the rib centre. The sheets should be installed with compatible proprietary interlocking Clip730 clips, which lock over the male rib. The clips lock firmly into the underside of the centre and female ribs and in turn are fastened to support with three fasteners. The clip shall be concealed where no fasteners can penetrate the roofing.

Lengths

On site roll-forming from ridge to eave, i.e. single jointless sheet or custom cut

Tolerances

Thickness for Material : $\pm 0.03\text{mm}$
 Effective Width : $\pm 4\text{mm}$
 Length : $\pm 0-15\text{mm}$

Dimension

Rib Height : 39mm
 Effective Cover : 730mm
 Minimum Roof Pitch : 1°

Maximum Roof Run (m) as based on CSIRO* Formula

	Rainfall Intensity mm/hr	Roof Slope					
		1°	2°	3°	5°	7.5°	10°
TH Clip Lock Optima 730	100	258	321	377	469	559	642
	150	172	214	251	312	373	428
	200	129	161	188	234	279	321
	250	103	128	151	187	224	257
	300	86	107	126	156	186	214
	400	65	80	94	117	140	161
	500	52	64	75	94	112	128

*Commonwealth Scientific & Industrial Research Organisation.
 The minimum recommended roof pitch is 1 degree.



Recommended Maximum Roof Length, Metre							
TH Clip Lock Optima 730	Rainfall Intensity, mm/hr	Roof Slope					
		1°	2°	3°	4°	5°	7.5°
	250	103	128	151	187	224	257
	300	86	107	126	156	186	214
	400	65	80	94	117	140	161
	500	52	64	75	94	112	128

Maximum Support Spacing; Roof, mm			
TH Clip Lock Optima 730	Type of Span	Base Metal Thickness, mm	
		0.42	0.48
	Single Span	1300	1600
	End Span	1350	1700
	Internal Span	2200	2400
	Unstiffened Overhang	100	150
	Stiffened Overhang	300	450

Based on AS1562.1-1992, AS4040.1-1992 & AS4040.2-1992 and wind speed VB= 47m/s, and supported on 1mm BMT
 Cpe = -1.2 (internal spans) Cpe = -2.0 (single and end span) Cpi = +0.2

Limit State Wind Pressure Capacities (KPa) - AS 1562.1992 - Roof 0.42mm BMT										
TH Clip Lock Optima 730	Span Type	Limit State	Span, mm							
			900	1200	1500	1800	2100	2400	2700	3000
	Single	Serviceability	1.63	1.32	1.03	0.77	0.56	0.41	0.31	0.23
		Strength	3.05	2.56	2.09	1.68	1.36	1.14	1.01	0.93
	End	Serviceability	1.53	1.43	1.36	1.19	0.96	0.74	0.58	0.47
		Strength	2.86	2.34	1.91	1.62	1.44	1.31	1.18	1.03
	Internal	Serviceability	1.57	1.40	1.23	1.07	0.93	0.81	0.70	0.61
		Strength	2.51	2.26	2.01	1.78	1.58	1.40	1.24	1.11

A capacity reduction factor of $\phi=0.9$ has been applied to strength capacities. The pressure capacities for serviceability are based on a deflection limit of (span/120) + (maximum fastener pitch/30). The pressure capacities for strength have been determined by testing the roofing for failure (ultimate capacity). These pressures are applicable when the roofing is fixed to a minimum of 1.0mm, G550 steel purlin.

Available Thickness							
TH Clip Lock Optima 730	Preferred Base Metal Thickness, mm	Total Coated Thickness, mm	Weight Per Metre, Kg/m ²	Weight Per Metre, Kg/m	Coverage Per Ton, M ² /MT	Steel Grade	Min Yield Strength, Mpa
	0.42	0.48	4.34	3.17	230	ASTM A446-E	550
	0.48	0.53	4.96	3.62	201	ASTM A446-E	550
	0.55	0.60	5.69	4.15	175	ASTM A446-E	550

Other thickness are subject upon stock availability and time delivery
 0.48 available for Clean Colorbond only. 0.47 available for Prima Maju, Primero, Zinalume & PPGI

TH Clip Lock Optima 730 : Limit state wind pressure capacities (KPa)

Span Type	Limit State	Span (mm)										
		900	1200	1500	1800	2100	2400	2700	3000	3300	3600	3900
TH Clip Lock Optima 730 mm Base Metal Thickness (0.47 mm Total Coated Thickness)												
SINGLE	Serviceability	1.63	1.32	1.03	0.77	0.56	0.41	0.31	0.23	0.18	-	-
	Strength*	3.05	2.56	2.09	1.68	1.36	1.14	1.01	0.93	0.88	-	-
END	Serviceability	1.43	1.43	1.36	1.19	0.96	0.74	0.58	0.47	0.39	0.34	-
	Strength*	2.86	2.34	1.91	1.62	1.44	1.31	1.18	1.03	0.88	0.72	-
INTERNAL	Serviceability	1.57	1.40	1.23	1.07	0.93	0.81	0.70	0.61	0.53	0.45	0.38
	Strength*	2.51	2.26	2.01	1.78	1.58	1.40	1.24	1.11	0.99	0.89	0.78
TH Clip Lock Optima 730 mm Base Metal Thickness (0.50 mm Total Coated Thickness)												
SINGLE	Serviceability	2.17	1.81	1.46	1.14	0.88	0.68	0.52	0.40	0.30	-	-
	Strength*	3.68	3.06	2.47	1.98	1.62	1.42	1.35	1.35	1.35	-	-
END	Serviceability	2.20	1.84	1.51	1.23	1.00	1.82	0.67	0.55	0.45	0.35	-
	Strength*	3.36	2.87	2.41	2.02	1.69	1.42	1.20	1.02	0.87	0.73	-
INTERNAL	Serviceability	2.00	1.96	1.89	1.74	1.50	1.22	0.95	0.74	0.67	0.67	0.67
	Strength*	3.10	2.75	2.43	2.13	1.88	1.67	1.49	1.35	1.23	1.14	1.05

* A capacity reduction factor of $\phi=0.9$ has been applied to strength capacities. Support must be not less than 1 mm BMT

FASTENERS - SELF DRILLING SCREW

Fasteners without insulation						
	Support Details	Numbers of Fasteners			Clip Fixing	
		Per Sheet/support	Per m ²	Clips per m ²	Roof & Wall Application	
TH Clip Lock Optima 730	Steel up to 0.75mm BMT	3	4	1.5	15-15 x25, batten Tekes, Hex Head	
	Steel > 0.75mm BMT up to 3mm BMT				12-14 x 20, Metal Tekes, Hex Head	
	Timber - softwood				12-11 x 40, Type 17 HG, Hex Head	
	Timber - hardwood				12-11 x 25, Type 17 HG, Hex Head	

All fasteners shall comply with AS3566 -2002 Class 3 (minimum) for external application

Where insulation is to be installed, you may need to increase the length of the screw given above, depending on the density and thickness of the insulation.

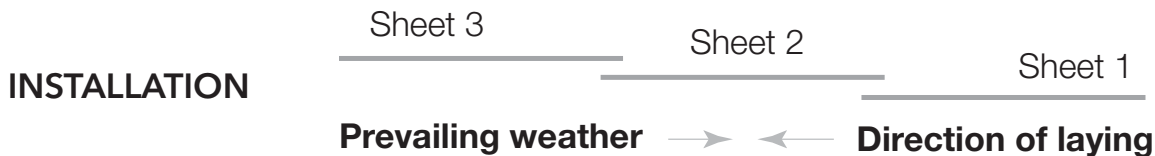

Preparation

Before starting work ensure that:

- The support for your cladding is truly in the same plane
- The minimum roof slope conforms to our recommendation
- The overhang of sheets from the top and bottom supports don't exceed our recommendations

Orientation of Sheet before Lifting

Consider which end of the building is best to start from. For maximum weather - tightness, start laying sheets from the end of the building that will be downwind of the worst - anticipated or prevailing weather.

It is much easier and safer to turn sheets on the ground than up on the roof. Before lifting sheets onto the roof, check that they are the correct way up and the overlapping side is towards the edge of the roof from which installation will start.

Place bundles of sheet over or near firm support, not at mid span of the roof members.

TH[®] CLIP LOCK 710



SECTIONAL PROFILE

Dimension

RIB height : 39mm
 Effective cover : 710mm
 Minimum roof pitch : 1°

Tolerance

Thickness of material : ±0.03mm
 Effective width : ±3mm
 Finishing length : ±5mm

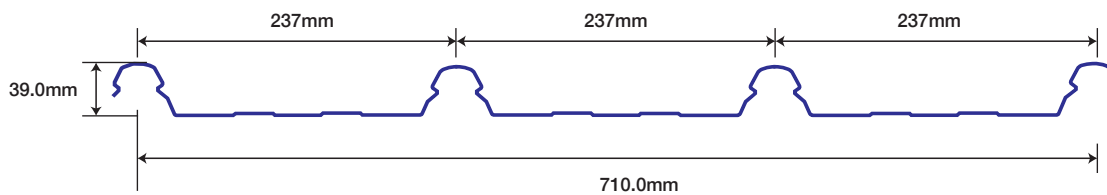

710 (Effective cover width) (All dimensions are in mm)

- Long length high tensile metal roofing.
- Combines with smart fluted spans and a lock-action rib design.
- Steel substrate protected with corrosion inhibitive treatment.
- Roofing and walling profiles with material warranty up to 25 years*.
 * Warranty terms & conditions apply.
- Wider effective coverage width of 710mm and rib height of 39mm.
- Minimum roof pitch of 1°.
- Concealed fixing method with clip and locking system.
- Suitable for low pitched roofs like petrol stations, warehouses, exhibition halls, shop offices etc.

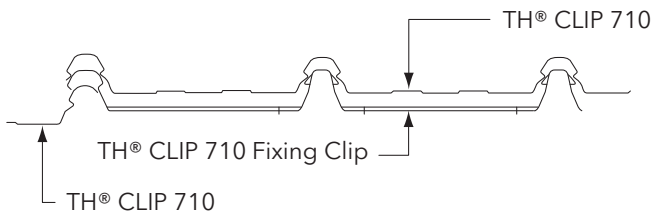

TH® CLIP 710 with Fixing Clip



TH® CLIP 710 with Fixing Clip

TECHNICAL SPECIFICATIONS

AVAILABLE THICKNESS

Base Metal Thickness (mm)	Total Coated Thickness (mm)	Weight per metre (kg/m)	Weight per sq metre (kg/m ²)	Coverage per ton (m ² /MT)	Steel Grade	Minimum Yield Strength (MPa)
0.35	0.40	2.67	3.77	265	ASTM A446-E	550
0.42	0.48	3.18	4.48	223	ASTM A446-E	550
0.48	0.53	3.61	5.08	197	ASTM A446-E	550

Base metal thickness (BMT) available are 0.35mm, 0.42mm & 0.48mm. Other thickness is upon request & available.

Other thickness are subject upon stock availability and time delivery

0.48 available for Clean Colorbond only. 0.47 available for Prima Maju, Primero, Zinalume & PPGI

MINIMUM FALL

The amount of water that must be shed increases with the length of the roof. To avoid possible back-up of water in severe wind conditions, the following recommended roof length should be considered as maximum for a given roof pitch and rain fall rate.

RECOMMENDED MAXIMUM ROOF LENGTH (M)

SLOPE IN DEGREE RAINFALL (mm/h)	1°	2°	3°	5°	7.5°
250	130	168	198	245	290
300	110	142	165	200	247
400	85	99	120	155	185
500	67	85	100	124	148

DISTRIBUTED LOAD CAPACITY - CONTINUOUS SPAN CONDITION

Thickness (mm) (TCT)	SPAN	mm	900	1050	1200	1350	1500	1650	1800	1950	2100
0.48	Serviceability	kPa	3.07	2.50	2.10	1.55	1.16	0.88	0.66	0.51	0.38
	Strength	kPa	4.90	4.11	3.61	2.93	2.32	1.88	1.56	1.30	1.04
0.53	Serviceability	kPa	4.25	3.37	2.56	1.86	1.29	0.93	0.67	0.58	0.51
	Strength	kPa	6.31	5.22	4.23	3.38	2.75	2.20	1.81	1.62	1.44

MAXIMUM RECOMMENDED SPACING OF SUPPORTS

Thickness (mm) (TCT)	ROOF			WALL			Max Roof Overhand Unsupported (mm)
	Single Span	End Span	Internal Span	Single Span	End Span	Internal Span	
	mm	mm	mm	mm	mm	mm	
0.48	1600	1700	2200	2400	3000	3600	250
0.53	2000	2300	2800	2700	3300	3900	300

Note: - The roof overhang is not meant for human traffic.

All thickness are nominal and provisional. Tolerance may occur and it is subjected to change and variations in accordance to finished product's condition.

TH[®] CLIP 760



TH[®] CLIP 760 with Fixing Clip

SECTIONAL PROFILE

Dimension

RIB height	:	25mm
Effective cover	:	760mm
Minimum roof pitch	:	3°

Tolerance

Thickness of material	:	±0.03mm
Effective width	:	±3mm
Finishing length	:	±5mm

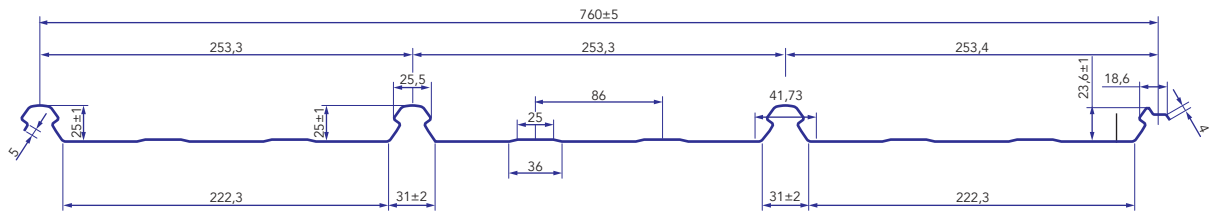

760 (Effective cover width) (All dimensions are in mm)

- Long length high tensile metal roofing.
- Combines with smart fluted spans and a lock-action rib design.
- Steel substrate protected with corrosion inhibitive treatment.
- Roofing and walling profiles with material warranty up to **30 years***.
- * Warranty terms & conditions apply.
- Coverage width of 760mm and rib height of 25mm.
- Minimum roof pitch of 3°.
- Concealed fixing method with clip and locking system.
- Suitable for **residential & commercial**.

Installation Method

STEP 1

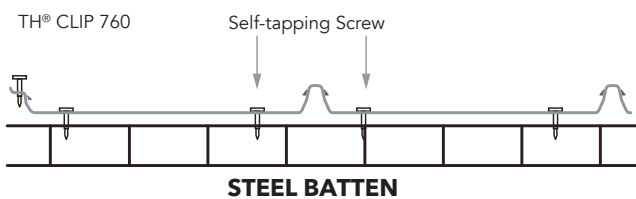

Secure the **TH® CLIP 760** to the roof batten using self-tapping screws. Ensure proper alignment along the purlin for optimal load transfer.

STEP 2

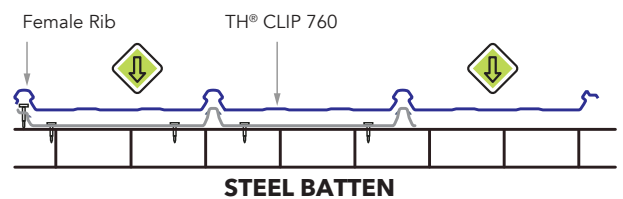

Position the **TH® CLIP 760** panel and press it firmly down onto the TH fixing clip until the clip engages with the panel rib.

STEP 3

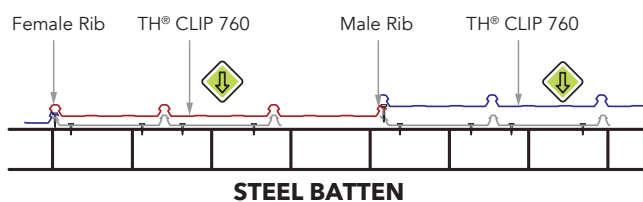

Before placing the next new sheet, drive the fastener through both the male rib and female rib together, securing them firmly to the batten beneath. This locks the two ribs into position and prepares the seam for the overlapping panel.

STEP 4

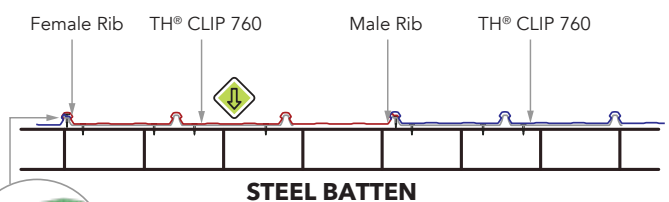

Finally, place the next new sheet over the fastened ribs. The new panel's male rib will cover the fastener completely, leaving no exposed screw heads on the finished roof.

TECHNICAL SPECIFICATIONS

AVAILABLE THICKNESS

Base Metal Thickness (mm)	Total Coated Thickness (mm)	Weight per metre (kg/m)	Weight per sq metre (kg/m ²)	Coverage per ton (m ² /MT)	Steel Grade	Minimum Yield Strength (MPa)
0.35	0.40	2.67	3.77	265	ASTM A446-E	550
0.42	0.48	3.18	4.48	223	ASTM A446-E	550
0.48	0.55	3.61	5.08	197	ASTM A446-E	550

Base metal thickness (BMT) available are 0.35mm, 0.42mm & 0.48mm. Other thickness is upon request & available.

MINIMUM FALL

The amount of water that must be shed increases with the length of the roof. To avoid possible back-up of water in severe wind conditions, the following recommended roof length should be considered as maximum for a given roof pitch and rain fall rate.

RECOMMENDED MAXIMUM ROOF LENGTH (M)

SLOPE IN DEGREE RAINFALL (mm/h)	3°	4°	5°	6°	7°
250	150	200	250	>250	>250
300	120	170	220	250	>250
400	95	145	195	240	>250
500	85	115	144	180	220

DISTRIBUTED LOAD CAPACITY - CONTINUOUS SPAN CONDITION

Thickness (mm) (TCT)	SPAN	mm	900	1050	1200	1350	1500	1650	1800	1950	2100
0.48	Serviceability	kPa	3.07	2.50	2.10	1.55	1.16	0.88	0.66	0.51	0.38
	Strength	kPa	4.90	4.11	3.61	2.93	2.32	1.88	1.56	1.30	1.04
0.55	Serviceability	kPa	4.25	3.37	2.56	1.86	1.29	0.93	0.67	0.58	0.51
	Strength	kPa	6.31	5.22	4.23	3.38	2.75	2.20	1.81	1.62	1.44

MAXIMUM RECOMMENDED SPACING OF SUPPORTS

Thickness (mm) (TCT)	ROOF			WALL			Max Roof Overhand Unsupported (mm)
	Single Span	End Span	Internal Span	Single Span	End Span	Internal Span	
	mm	mm	mm	mm	mm	mm	
0.48	1600	1700	2200	2400	3000	3600	250
0.55	2000	2300	2800	2700	3300	3900	300

Note: - The roof overhang is not meant for human traffic.

All thickness are nominal and provisional. Tolerance may occur and it is subjected to change and variations in accordance to finished product's condition.

TH[®] LOCKSEAM 75



TH[®] Lock-Seam 75 is a high-performance standing seam roofing system designed for modern industrial and commercial buildings. It delivers exceptional strength, weatherproofing, and long-span capability—ideal for projects requiring durability, precision, and long-term reliability.

SECTIONAL PROFILE

Dimension	Tolerance
RIB height : 75mm	Thickness of material : ±0.03mm
Effective cover : 470mm	Effective width : ±3mm
Minimum roof pitch : 1°	Finishing length : ±5mm

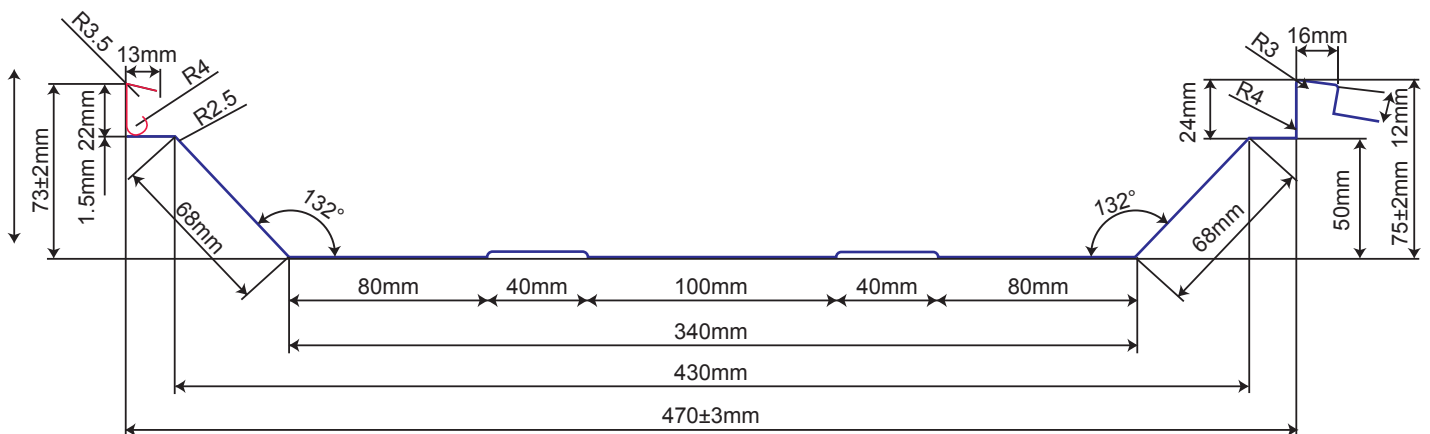

470±3 (Effective cover width) (All dimensions are in mm)

- **High Rib for Superior Drainage & Bold Aesthetics:** The impressive 75mm rib height delivers excellent water flow capacity and adds a bold, architectural look ideal for industrial and commercial projects.
- **Optimized Panel Width:** 470mm panel width provides a streamlined, defined appearance with precise alignment during installation.
- **Concealed Clip System for Clean & Secure Fixing:** Hidden clip system enhances water resistance, allows for thermal expansion, and ensures a neat, screw-free finish.
- **Supports Long-Length Installation:** Engineered to accommodate long-length panels, reducing end laps and potential leakage points - perfect for large-span roof designs.

Section Properties

Thickness mm (BMT)	Weight Per M ² (Kg/m ²)	Coverage per Tone (m ²)
0.42	4.43	225
0.48	5.03	198
0.60	6.23	160
0.75	7.74	129

STRUCTURAL PERFORMANCE				
Distributed Load Capacity				
(Extrapolated for higher thickness)				
BMT	Span	900mm	1200mm	150mm
0.42mm	Strength (kPa)	3.78	2.90	1.70
	Serviceability (kPa)	2.32	1.67	0.85
0.48mm	Strength (kPa)	4.88	3.50	2.30
	Serviceability (kPa)	3.02	2.07	3.50
0.60mm	Strength (kPa)	7.00	7.00	1.15
	Serviceability (kPa)	4.30	5.00	5.00
0.75mm	Strength (kPa)	9.50	3.00	1.80
	Serviceability (kPa)	6.00	4.20	2.80

TH VERTICAL STANDING SEAM

FOR RESIDENTIAL, COMMERCIAL & INDUSTRIAL

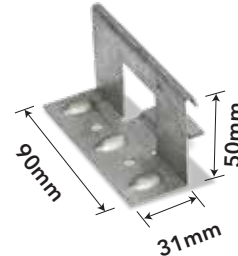

SECTIONAL PROFILE

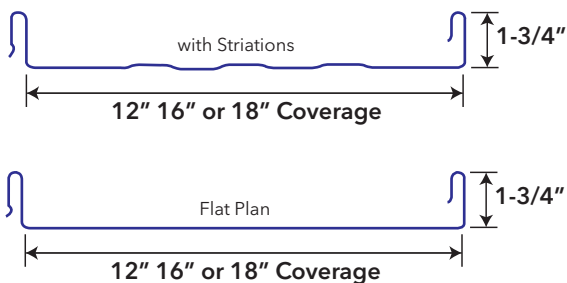

Vertical Seam Attachment Detail

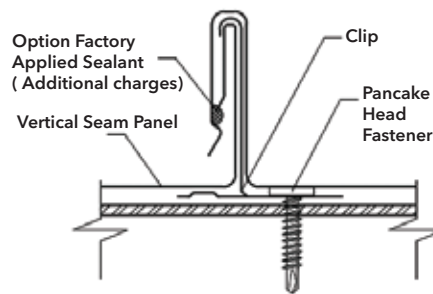

Vertical Seam Panel Clip

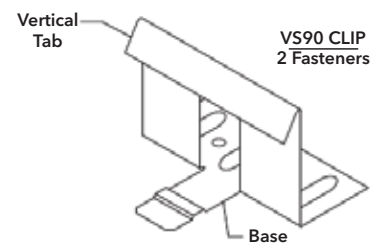

- Architectural/structural integral standing seam panel
- 12", 16", and 18" panel coverage, 1-3/4" rib height
- Gauges: 26 Gauge and 24 Gauge standard
- Snap together panel system, minimum roof slope: 3:12
- Factory applied side lap sealant (option)
- Concealed clip designed for thermal movement
- Accommodates up to 4" blanket insulation
- Applies over open framing or solid substrate
- Finishes: Clear Colorbond, PVDF Aluminium

VERTICAL SEAM METAL PANEL GENERAL INFORMATION

Slope:	The minimum recommended slope for the Vertical Seam roof panel is 3:12.
Substructure:	Vertical Seam is designed to be utilized over open structural framing or a solid substrate.
Clips:	Clip spacing is based upon the spacing of structural framing members and loading requirements. Concealed clip designed for thermal movement.
Gauges:	26 Gauge and 24 Gauge standard
Coverage:	Vertical Seam panels are architectural/structural integral standing seam panel, available in a 1-3/4" seam height with a 12", 16", or 18" width coverage. Accommodates up to 4" blanket insulation - Snap together panel system; factory applied side lap sealant. Architectural/structural integral standing seam panel.
Length:	Minimum factory cut length is 4'-0". Maximum recommended panel length is 45'-0". Longer panels require additional consideration in packaging, shipping, and erection. Please contact us for recommendations enquiries@thunghing.com
Fasteners:	The fastener selection guide should be consulted for choosing the proper fastener for specific applications. Quantity and type of fastener must meet necessary loading and code requirements. NOTE: All panels are subject to surface distortion due to improperly applied fasteners. Overdriven fasteners will cause stress and induce oil canning across the face of the panel at or near the point of attachment.
Finishes:	Clear Colorbond, PVDF Aluminium
Testing:	<ul style="list-style-type: none"> • ASTM E-1646 Water Penetration • Wind uplift test

TH SPANDEX



TH SPANDEX is a modern and trapezoidal profile which combines strength with lightness, rigidity and economy.

TH SPANDEX was originally designed as a strong attractive roofing material for industrial and commercial construction, however **TH SPANDEX** has proved equally popular for home and public buildings, underlining its versatility and pleasing appearance.

DIMENSION

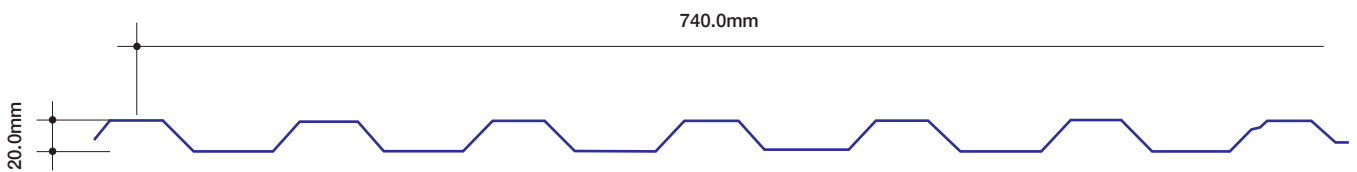

SAMPLES OF SPECIFICATION

TH SPANDEX® 0.47mm Total Coating Thickness (TCT) roofing sheets in AZ150 G550 **Clean Colorbond XRW Steel /Prima Maju AZ100 / Primero Z180 / PPGI** pierced fastened with self drilling screws with hex, washer head and EPDM seal - Complying to AS3566 Class 3 minimum; fixed to metal purlins.

- Highly serviceable roofing and walling cladding
- Trapezoidal ribs can be run vertical or horizontally
- Conformity to international building codes and standard
- Speedy fixing and lower installation cost
- A special anti-capillary groove

TYPICAL WALL BUILD UP

TH SPANDEX SINGLE SKIN ROOF

1. TH SPANDEX 0.42mm BMT Cladding Sheet in AZ150 G550 Clean Colorbond® XRW Steel /Prima Maju AZ100 / Primero Z180 / PPGI
2. 1 Layer of 1mm thk GI ZED-Spacer
3. 1 Layer of 50mm thk Mineral Wool Insulation
4. 1 Layer of 6mm Cemboard
5. TH C-Purlin

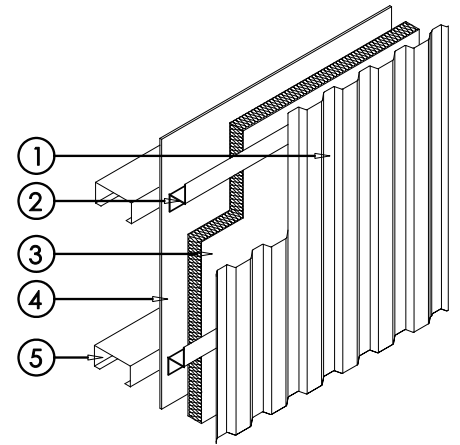

TH SPANDEX DOUBLE SKIN WALL CLADDING

1. TH SPANDEX 0.42mm BMT Roofing Sheet in AZ150 G550 Clean Colorbond® XRW Steel /Prima Maju AZ100 / Primero Z180 / PPGI
2. 1 Layer of 1mm thk GI ZED-Spacer
3. 1 Layer of 50mm thk Mineral Wool Insulation
4. TH SPANDEX 0.42mm BMT Cladding Sheet in AZ150 G550 Zinalume® Steel
5. TH C-Purlin

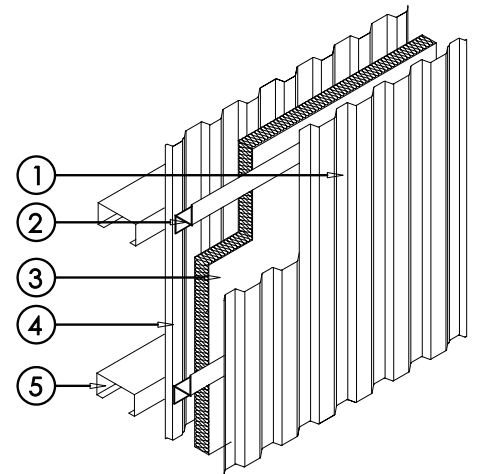

TECHNICAL SPECIFICATIONS

Thickness						
BMT in mm		0.35	0.42		0.4	
TCT in mm		0.40	0.48		0.53	
Effective Coverage Width (mm)		740	740		740	
Rib Height (mm)		20	20		20	
Tolerance						
Effective cover width		±3mm				
Mass	Zinalume	Clean Colorbond	Zinalume	Clean Colorbond	Zinalume	Clean Colorbond
Mass per unit area kg/m ²	3.60	3.67	4.28	4.35	4.86	4.94
Mass per unit length kg/m	2.67	2.72	3.17	3.22	3.60	3.65
Maximum Allowable Support Spacings Roof Applications						
Single span (mm)		1400		1500		1600
End span (mm)		1400		1500		1600
Internal Span (mm)		1600		1700		1800
Overhang (mm)		100		100		150
Wall applications						
Single span (mm)		1500		1600		1700
End span (mm)		1500		1600		1700
Internal Span (mm)		1700		1800		1900
Overhang (mm)		150		150		200
Minimum Pitch						
Sheet Length		3°				
Grade of steel		G550 (550N/mm ² yield strength)				
Coating Class (min)		AZ150				

Other thickness are subject upon stock availability and time delivery
 0.48 available for Clean Colorbond only. 0.47 available for Prima Maju, Primero, Zinalume & PPGI

METHOD STATEMENT AND GENERAL NOTES

WALKING ON ROOFS

Generally, keep your weight evenly distributed over the soles of your feet to avoid concentrating your weight on either heels or toes. Always wear smooth softsoled shoes; avoid ribbed soles that pick up and hold small stones, swarf and other objects.

WHEN WALKING ACROSS THE WIDTH OF THE ROOF, WALK OVER, OR CLOSE TO, THE ROOF SUPPORTS.

Fasteners Without Insulation		
	Fixing To Steel	Fixing To Timber
Crest Fixed	Self Drilling Screws With Hex. Washer-Head & EPDM Seal, 12 x 45mm	Self Drilling Screws With Hex. Washer-Head & EPDM Seal, 10 x 50mm
Valley Fixed	Self Drilling Screws With Hex. Washer-Head & EPDM Seal, 12 x 20mm	Self Drilling Screws With Hex. Washer-Head & EPDM Seal, 10 x 25mm
Side Lap & Accessories	Self Drilling Screws With Hex. Washer-Head & EPDM Seal, 12 x 20mm	Self Drilling Screws With Hex. Washer-Head & EPDM Seal, 10 x 20mm

FASTENERS

TH SPANDEX requires 5 fasteners per sheet per support as shown below. Fasteners should comply to AS3566, Class 3 and Class 4.

Side-laps

The edge of **TH SPANDEX** with the anti-capillary groove is always the underlap (see figures on this page). It is generally considered good practice to use fasteners along side-laps however, when cladding is supported as indicated in Maximum Support Spacings, side-lap fasteners are not usually needed for strength.

End lapping

End-laps are not usually necessary because **TH SPANDEX** is available in long lengths. If you want end-laps, seek advice from our information line on the sequence of laying and the amount of overlap.

Ends of sheets

It is usual to allow roof sheets to overlap into gutters by about 50mm. If the roof pitch is less than 25° or extreme weather is expected, the valleys of sheets should be turned-down at lower ends, and turned-up at upper ends by about 80°.

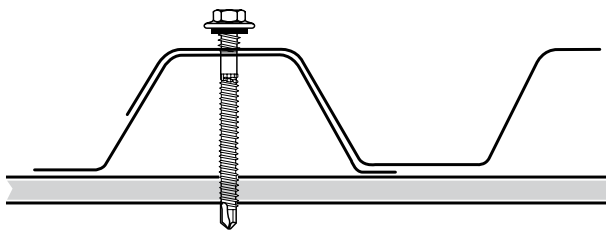

Crest fixing for roof or walls

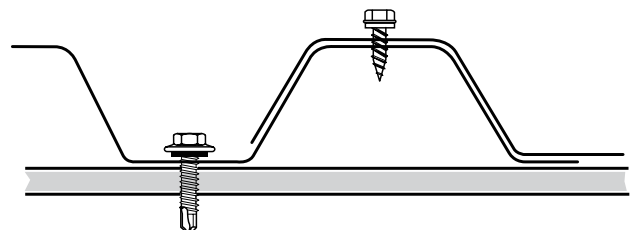

Valley fixing for walls only

TYPICAL ROOF BUILD UP

TH SPANDEX SINGLE SKIN ROOF

1. TH SPANDEX 0.42mm BMT Roofing Sheet in AZ150 G550
Clean Colorbond® XRW Steel /Prima Maju AZ100 /
Primer Z180 / PPGI
2. 1 Layer of 50mm thk Mineral Wool Insulation
3. 1 Layer of Double Sided Woven Aluminium Foil
4. TH C-Purlin

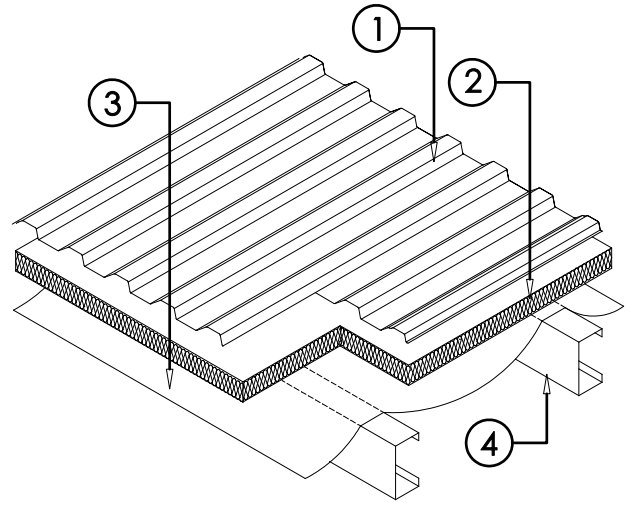

1. TH Clip Lock Optima 730 0.48mm BMT Roofing Sheet in AZ150
G550 Clean Colorbond® XRW Steel c/w TH CL73 Fixing Clips
2. 1 Layer of 1mm thk GI Zed-Spacer
2. 1 Layer of 50mm thk Mineral Wool Insulation
4. TH SPANDEX 0.42mm BMT Roofing Sheet in AZ150 G550
Zincalume® Steel
5. TH C-Purlin

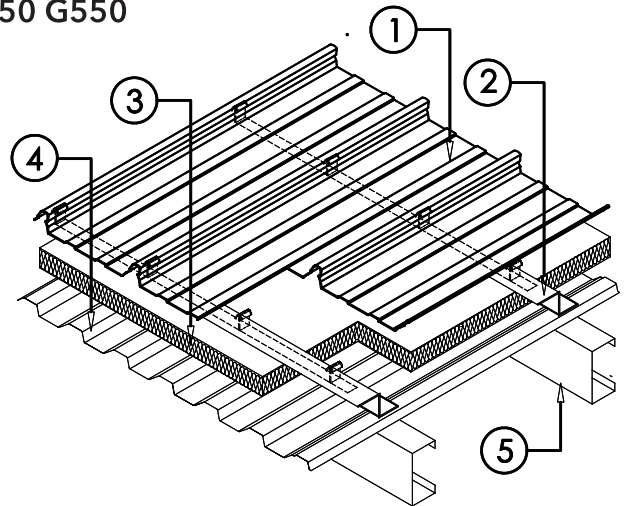

WATER RUN OFF

MAXIMUM ROOF LENGTHS FOR DRAINAGE MEASURED FROM RIDGE TO GUTTER (M)

Slope of Degree (mm/hr)	3°	5°	7°	10°	12°
250	24	31	37	44	48
300	20	26	31	36	40
350	17	22	26	31	34
400	15	20	23	27	30

CAPPING & FLASHING

We supply gutter, flashings and cappings standard or custom made. The finish can be plain **ZINCALUME®** steel or **Clean COLORBOND®** steel.

STANDARD CAPPING

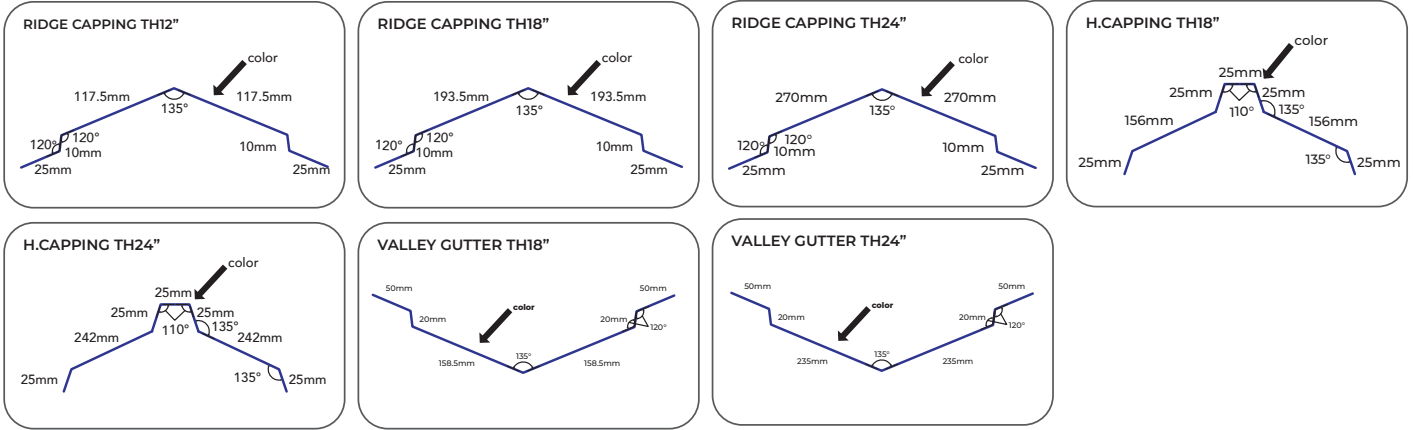

STANDARD FLASHING

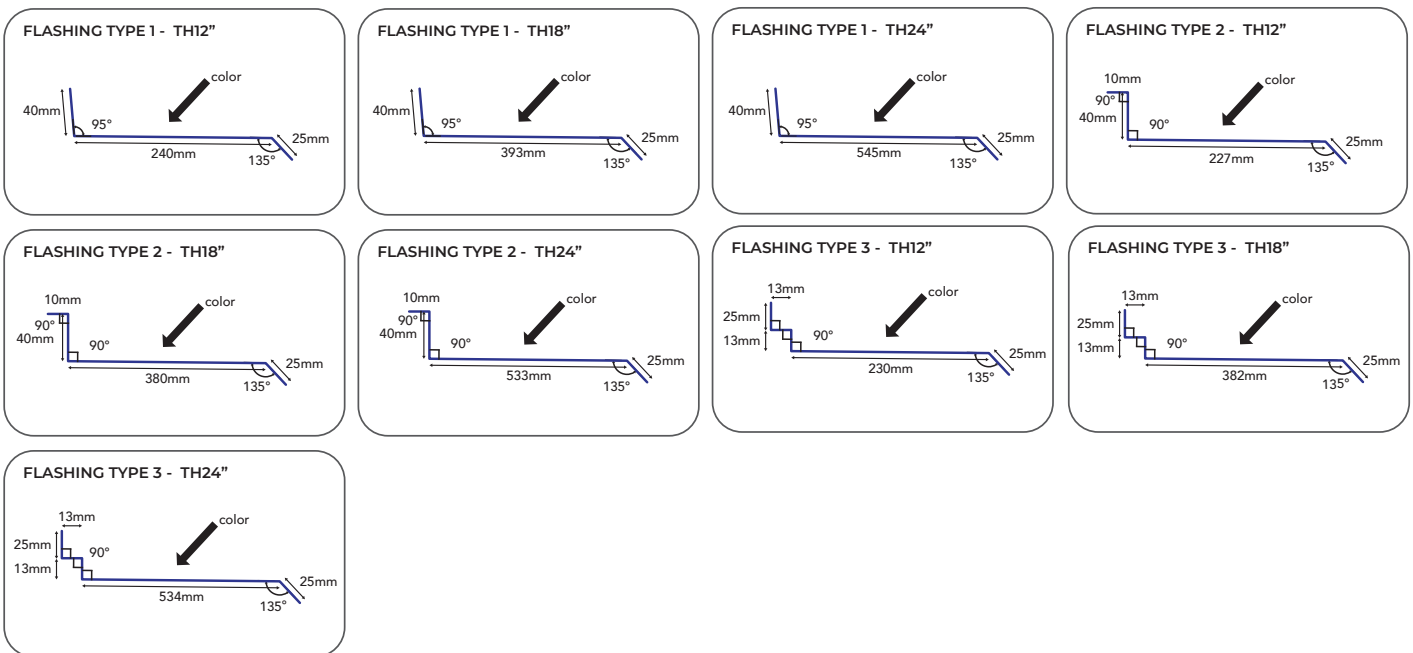

STANDARD FLASHING

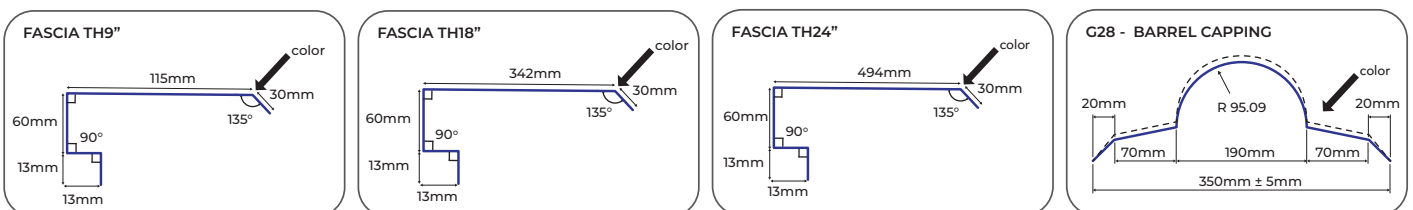

COLOUR SELECTION CHART

METAL ROOFING & WALLING SYSTEM



1. SEMARAK (SM)



2. TELANG (TL)



3. KABUS (KB)



★ 4. SENI BALI (SB)



★ 5. MARAKAN (MR)



★ 6. EMBUN (EB)



7. LADA PUTIH (LP)



★ 8. TANAH LIAT (TN)



★ 9. KASTURI (KS)



★ 10. SALJI (SL)



11. MENDUNG (MD)



12. PANDAN (PD)



13. ZINCALUME (ZAC) /
ALUZINC



★ 14. CHARCOAL GREY (CG)



★ 15. YELLOW (YL)

★ :SPECIAL COLOUR

*Term and Conditions Applied

Note: All colour shown above are close to the actual Thung Metal Roofing steel colour as the limitations of the printing process may affect the actual colour tone.

CENTRAL REGION

SELANGOR DARUL EHSAN :

No 7, Jalan Platinum 3, Presint 2, Bandar Industri Bernilai Tinggi Serendah, 48200 Serendah, Selangor.
Tel : +603-6099 9999 / 9988 Fax : +603-6099 9922 / 9933

Serai Harmoni Sdn Bhd (1053281-W)

No 9, Jalan Platinum 3, Presint 2, Bandar Industri Bernilai Tinggi Serendah, 48200 Serendah, Selangor.
Tel : +603-6099 9999 / 9988 Fax : +603-6099 9922 / 9933

NORTHERN REGION

KEDAH DARULAMAN :

No. E2, Jalan Cendana 4/5, Kaw. Perindustrian Cendana, 08000 Sungai Petani, Kedah Darul Aman, Malaysia.
Tel : +604-430 0321(HL) +604-430 4335 / 4568 Fax : +604-430 4393 / 4348 / 4849 H/P : +6012-381 9218

PERAK DARUL RIDZUAN :

Lot 111940, Jalan Lahat, 31450 Menglembu, Perak Darul Ridzuan, Malaysia.
Tel : +605-282 1844 Fax : +605-2820 844 H/P : +6017-360 1218

170, Hala Perusahaan Menglembu 1, Kawasan Prindustrian Menglembu, 31450 Ipoh Perak Darul Ridzuan, Malaysia.
Tel : +605-282 1844 Fax : +605-2820 844 H/P : +6017-360 1218

EAST COAST EAST MALAYSIA

KELANTAN DARUL NAIM :

Lot 1493, Kaw. Perindustrian Pengkalan Chepa II, Seksyen 44, Mukim Panchor, Daerah Kemumin, 16100 Kota Bharu, Kelantan Darul Naim, Malaysia.
Tel : +609-774 1127 / 1128 Fax : +609-774 1130 / 1131 H/P : +012-200 6335

TERENGGANU DARUL IMAN :

17446, Kawasan Perindustrian Wakaf Tapai, 21040 Marang, Terengganu Darul Iman, Malaysia.
Tel : +609-638 1216 Fax : +609-638 1219

SOUTHERN REGION

JOHOR DARUL TAKZIM :

Lot 4452, Pt. Kampung Abdul Rahman, 82200 Benut, Pontian, Johor Darul Takzim, Malaysia.
Tel : +607-690 9926 / 9929 Fax : +607-690 9928 H/P : +019-278 8788

EAST MALAYSIA

SABAH :

Lot No 19, Jalan 3 KKIP Timur, Industrial Zone 12, KKIP Telipok, 88460 Kota Kinabalu, Sabah, Malaysia.
Tel : +608 840 8919 H/P : +6019-280 6218

SARAWAK :

Lot 1259, Jalan Jentera, Bintawa Industrial Estate, 93450 Kuching, Sarawak, Malaysia.
Tel : +6082 552171

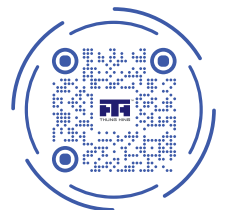

THUNG HING GROUP

W : www.thunghing.com.my **E** : enquiries@thunghing.com **f** : [Thung Hing group](https://www.facebook.com/ThungHingGroup) **@** : [thunghing.group](https://www.instagram.com/thunghing.group) **d** : [thunghing.group](https://www.youtube.com/channel/UC...)

The information and illustration contained herein are for guidance only. Care has been taken to ensure all data and information herein is factual and numerical values are accurate at the time of publication. However, any or all technical specification, information and dimensions are nominal and provisional; they are subjected to change and variations in accordance with market conditions at the date of factual supply. No representation is made or to be implied as to the data and information herein; THUNG HING GROUP, and its subsidiary and associate companies shall not be responsible for any errors in or misrepresentation of the information contained in this brochure or its use. THUNG HING GROUP, and its subsidiary and associate companies reserve the right to alter any or all specifications as deemed fit and necessary without prior notice.
Copyright © 2024 THUNG HING GROUP. All Rights Reserved.