



Delivering Excellence,
Building Solutions.

CREATING
EXCELLENCE
IN BUILDING SOLUTIONS

METAL DOOR
WINDOW FRAMES

FIRE RESISTANT DOORSET

CASEMENT WINDOW

ACOUSTIC



CENTRAL REGION

SELANGOR DARUL EHSAN :
Lot P. T. 1353, Jalan Kesidang 5,
Kaw. Industri Sg. Choh,
48000 Rawang,
Selangor Darul Ehsan, Malaysia
Tel : +603-6099 9999 / 9988
Fax : +603-6099 9922 / 9933

Serai Harmoni Sdn Bhd (1053281-W)
Lot P. T. 1362 & 1363, Jalan Kesidang 5,
Kaw. Industri Sg. Choh,
48000 Rawang,
Selangor Darul Ehsan, Malaysia
Tel : +603-6099 9833
Fax : +603-6099 9822



NORTHERN REGION

KEDAH DARUL AMAN :
No. E2, Jalan Cendana 4/5,
Kaw. Perindustrian Cendana,
08000 Sungai Petani,
Kedah Darul Aman, Malaysia
Tel : +604-430 0321(HL)
+604-430 4335 / 4568
Fax : +604-430 4393 / 4348 / 4849

PERAK DARUL RIDZUAN :
Lot 111940, Jalan Lahat,
31450 Menglembu,
Perak Darul Ridzuan, Malaysia
Tel : +605-2821 844
Fax : +605-2820 844

SOUTHERN REGION

JOHOR DARUL TAKZIM :
Lot 4452, Pt. Kampung
Abdul Rahman,
82200 Benut, Pontian,
Johor Darul Takzim, Malaysia
Tel : +607-690 9926 / 9929
Fax : +607-690 9928

EAST COAST

KELANTAN DARUL NAIM :
Lot 1493, Kaw. Perindustrian Pengkalan Chopu II,
Seksyen 44, Mukim Panchor, Daerah Kemumin,
16100 Kota Bharu, Kelantan Darul Naim, Malaysia
Tel : +609-774 1127 / 1128
Fax : +609-774 1130 / 1131

EAST MALAYSIA

SABAH :
Lot No. 11A, Jalan 3 KKIP Timur, Industrial Zone 13,
KKIP Telipok, 88460 Kota Kinabalu, Sabah, Malaysia
Tel : +6088 408 919
Fax : +6088 408 919
HP : 019-2678 817



THI HARDWARE TRADING SDN BHD (567864-W)

The information and illustration contained herein are for guidance only. Care has been taken to ensure all data and information herein is factual and numerical values are accurate at the time of publication. However, any of all technical specifications, information and dimensions are nominal and provisional. They are subjected to change and variations in accordance with market conditions at the date of actual supply. No representation is made or to be implied as to the data and information herein. THUNG HING GROUP and its subsidiary and associate companies shall not be responsible for any errors in or misrepresentation of the information contained in this brochure or its use. THUNG HING GROUP, and its subsidiary and associate companies reserve the right to alter any or all specifications as deemed fit and necessary without prior notice. Copyright © 2022 THUNG HING GROUP

Visit Us At:
THUNG HING GROUP



THI METAL DOOR & WINDOW FRAMES



THI Metal Door and Windows Frames are fully researched, designed and manufactured by Thung Hing's ISO 9001:2015 Quality Management System certified plant. This includes metal door accessories such as hinges, lock pocket/striker plate, lockset and many more.

Thung Hing emphasises producing high quality building material as the products form crucial parts of a building and the safety of the building occupants is utmost importance. Therefore, Thung Hing uses top quality metal material in producing its metal door and window frames. All THI™ Metal Doors and Window Frames are made from Zinalume® or Galvanneal coated metal. These materials have passed through the stringent local and international industrial quality standards as well as international client demands.

Thung Hing also ensures all products are made to last long and to withstand the forces of nature. All THI™ Metal Door and Window Frames are galvanization as well to protect if from rusting.

The sophisticated Cold Roll Forming technology used in the fabrication process also further enhances the frames durability and strength against impact.

The products has been utilised successfully nationwide in residential and government buildings. Many more upcoming projects will also be fitted with Thung Hing's large selection of designs.



With sophisticated roll-forming technology, we have the capabilities of producing precision and quality frames.

PRODUCT PROFILE OVERVIEW



Continuously improving,
adapting and refining our skill sets

PRODUCT PROFILE THI™

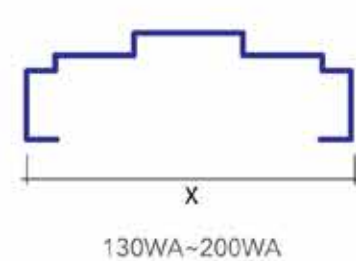
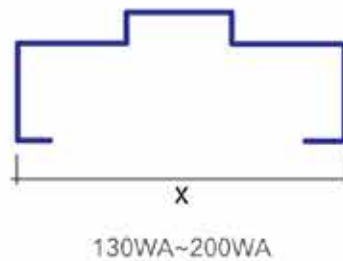
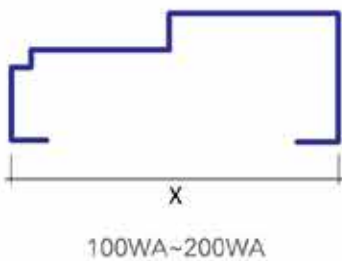

SPECIFICATIONS

Material

Hot-Dipped Galvanized, Electro Galvanized Steel,
Zincalume®, Galvanneal & Aluzin

Profile THI™

100WA, 105WA, 120WA, 130WA, 130KING,
140WA, 150WA, 160WA, 170WA, up to 200WA

Corners

Tagged, mitred, welded & treated

Accessories

- Hinges: Plated, 100mm loose pin slotted and welded into verticals, 3pcs per frame
- Striker Plate / Adaptor Bar
- Fish tail: 6pcs per frame

TECHNICAL DETAIL THI™ DOOR FRAME

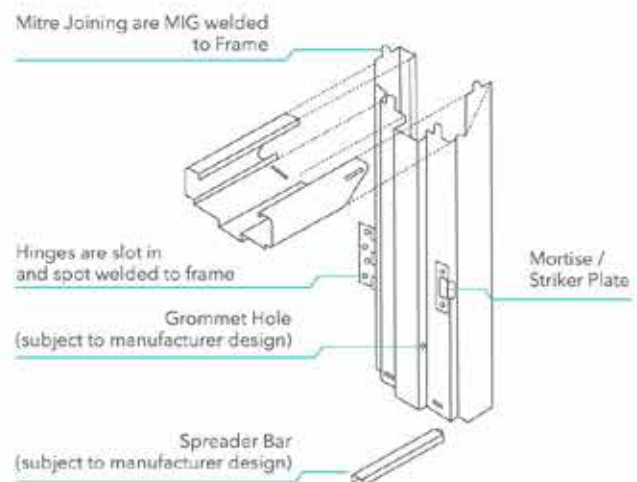

LOCATION OF HINGES / STRIKER PLATE & STRAP



Production processes with the goal of minimizing cost and maximizing value

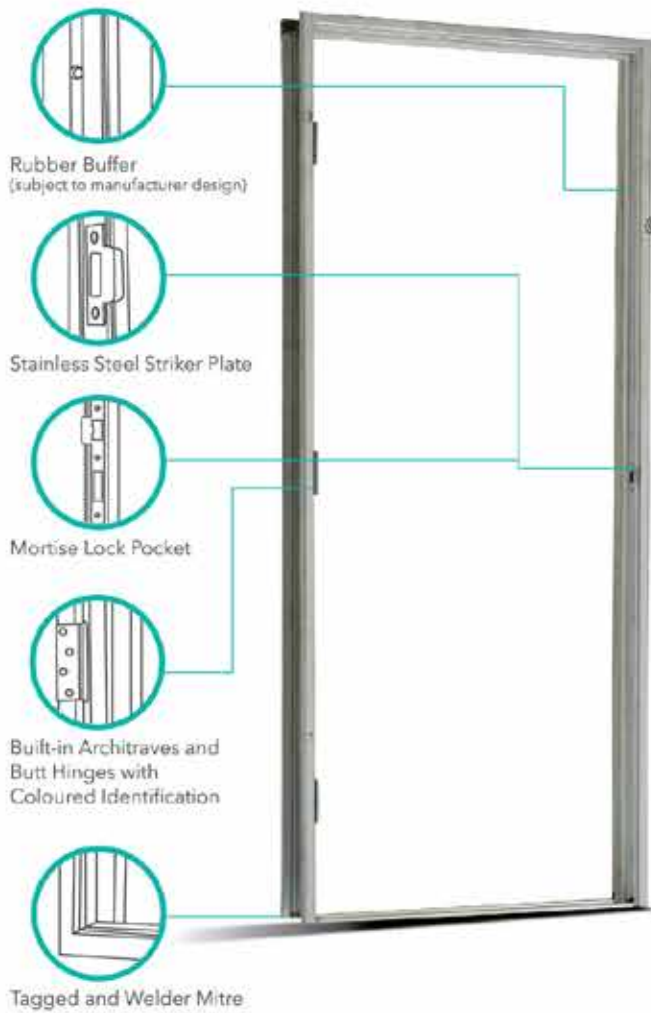

Details of typical cross section showing steel strap installation

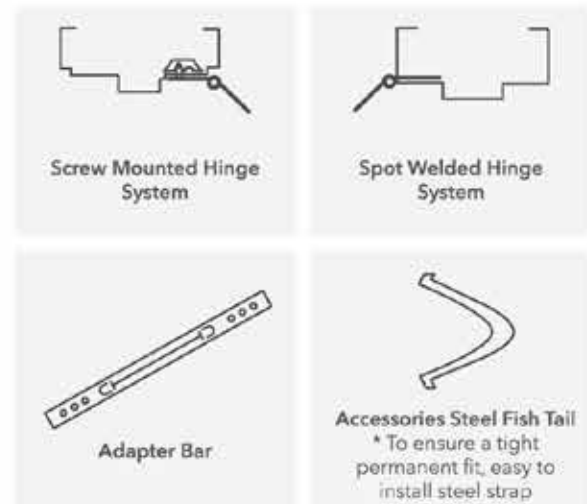
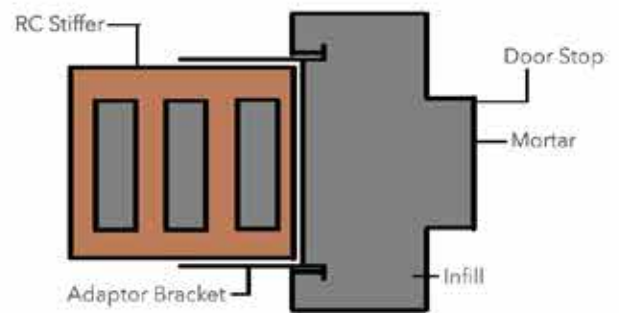

INSTALLATION PROCEDURE



Superior Product Performance with Design Flexibility



1 Mark out the area where the brickwork and the door is going to be



4 You can now proceed to lay the bricks into the rebate at the back of the frame



2 Use two lengths of timber to prop up door to standing position



5 It is important to place mortar into the gap between the brick and the frame. This is to ensure that the frame when filled with cement, will be extremely rigid and strong. Furthermore, the wall will be constructed with uniform thickness



3 Use a spirit to plumb the frame. When it's plumbed, secure the timber stays with a couple of bricks



6 Each metal door frame is supplied with a number of wire brick ties. Use them to tie brickwork every fourth or fifth brick course

ORDERING PROCEDURES

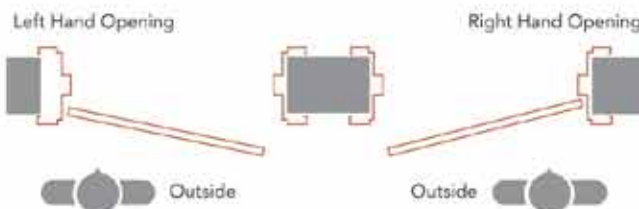

Always stand with the door opening toward you. The side with the hinges is determines the door opening (left hand or right hand)

When ordering, please specify:

1. Door frame size (External/Internal)
2. Door frame profile
3. Material type, width and thickness
4. Striker plate type
(ie: for mortise lock set or cylindrical lockset)
5. Left or right hand opening
6. Type of the Hinges
(a) GI Hinges (b) SUS 202 Hinges (c) SUS 304 Hinges

Tolerance : Thickness
for material ; $\pm 0.05\text{mm}$

Overall Profile Cross:
Section Width : $\pm 3\text{mm}$

MATERIAL COLOUR



Changing construction needs and evolving industry practices

THI™ FRAME PROFILES

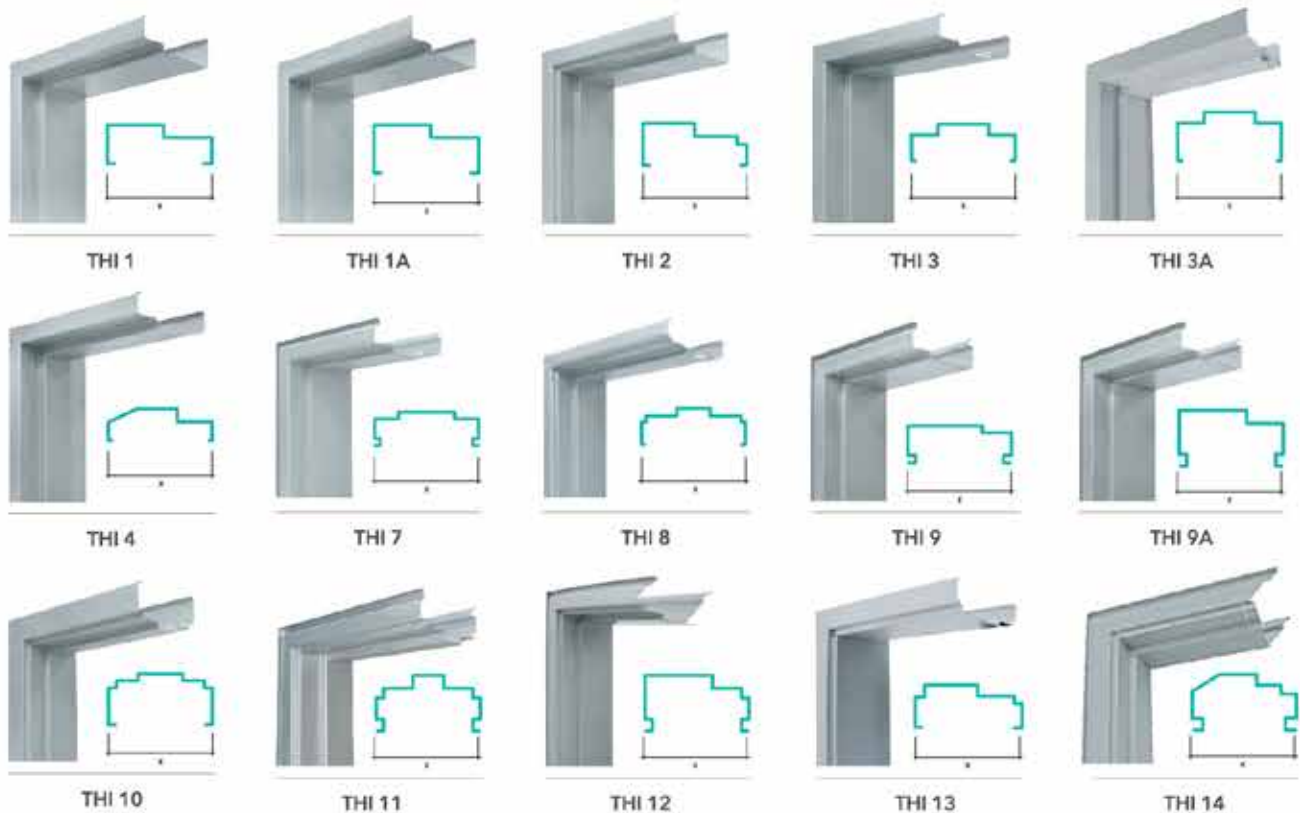

MATERIAL

Material thickness
 A. 0.80mm
 B. 1.0mm
 C. 1.20mm



Zinalume®



Hot-Dipped
(G. I.)



Electro Glvanized
(E.G.)



Galvanneal coated
steel (G. A.)



Zinalume®

CASEMENT WINDOW



- Modern design
- Faster & easy to install
- Save cost & times



front



Back

METAL CASEMENT WINDOW



4'(H) x 2'(W)



4'(H) x 4'(W)



4'(H) x 6'(W)

METAL SLIDING WINDOW



4'(H) x 4'(W)



4'(H) x 6'(W)

METAL TOP HUNG WINDOW



a) 18'(H) x 2'(W) b) 2'(H) x 2'(W)



a) 18'(H) x 4'(W) b) 2'(H) x 4'(W)



a) 18'(H) x 6'(W) b) 2'(H) x 6'(W)

THI 2 IN 1 DOOR FRAME WITH GRILLE

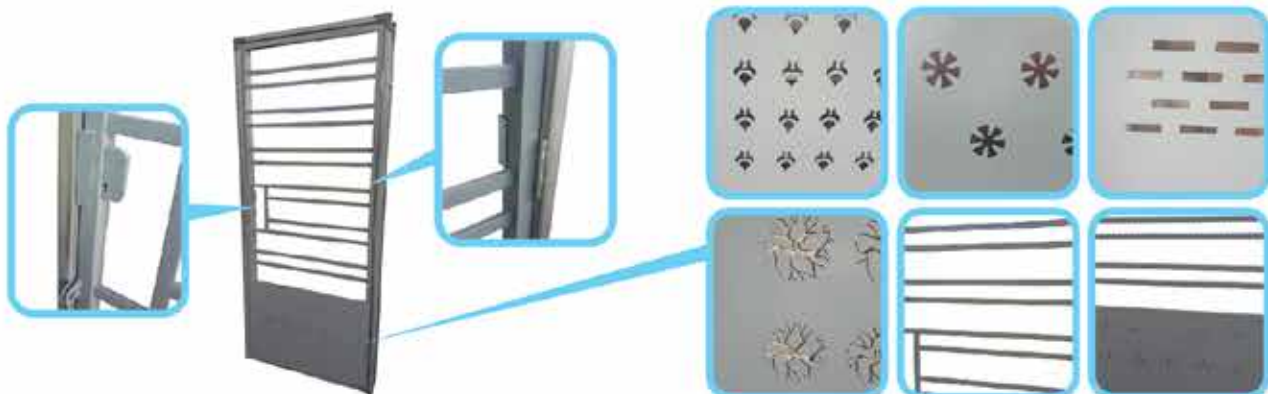

WARRANTY & CERTIFICATE

Superior Craftsmanship
with Elegant Hardwood Timber



* Terms and conditions apply



Certificates

THI™ Metal Doors and Window Frames are fully researched, designed and manufactured by Thung Hin's ISO 9001:2015 Quality Management System certified plant.



CERTIFIED TO ISO 9001:2015 (CERT. NO. 14100000000000000000)

FIRE RESISTANT DOORSETS



Delivering High Quality
Fire Resistant Doors

HARMONIDOOOR FIRE RESISTANT DOORSETS

Serai Harmoni Sdn Bhd manufactures Fire Resistant Doorsets based on ISO 9001:200 standards. With its sophisticated advanced technology, the company has the capabilities of producing precision quality products. **Serai Harmoni Sdn. Bhd.** Fire Resistant Doorsets & other accessories meet all domestic and international standards.

Serai Harmoni Sdn Bhd manufactures a full range of standard products that will suit any environment including residential, commercial industrial and JKR buildings.



DOUBLE LEAF

SINGLE LEAF

Approved by:



Certified by:



SERAI HARMONI
SDN. BHD.
(1053281-W)

+603-6099 9833
+603-6099 9822

enquiries@harmonidoor.com
www.harmonidoor.com

ADVANTAGES & ACCESSORIES

RESIDENTIAL

 <p>Samsung SHP-H60R Digital Door Lock</p>	 <p>Samsung SHS-H505 Digital Door Lock</p>	 <p>Samsung SHS-P717 Digital Door Lock</p>	 <p>Dormakaba Digital Lock M5</p>	 <p>Adel 1800 Digital Door lock</p>
 <p>MW-380 Smart Lock</p>	 <p>MILRE MI-6000</p>	 <p>Be-Tech biometric lock g536fk</p>	 <p>ST GUCHI SGDL809L</p>	 <p>YALE YMF30 Front Back</p>

HOTEL & COMMERCIAL

 <p>Orbita E3041 RFID Lock</p>	 <p>Vingard Signature RFID1</p>	 <p>Jenberg H1</p>	 <p>IDL100-101</p>	 <p>Adel 1800 RFID card</p>
--	---	--	--	---

ADVANTAGES

- High screw holding capacity amongst fire doors
- Excellent sound insulation and acoustic properties
- Constructed of superior quality wood base materials
- Treated with fire repellent with product finishes of exceptional quality

DOOR FRAME PROFILES

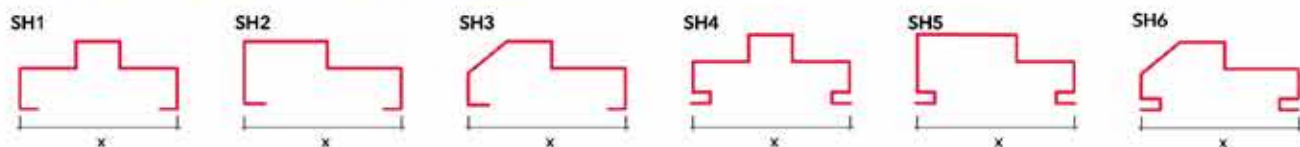

LOCKSET ACCESSORIES

HARMONIDOOR STAINLESS STEEL 304 HINGES

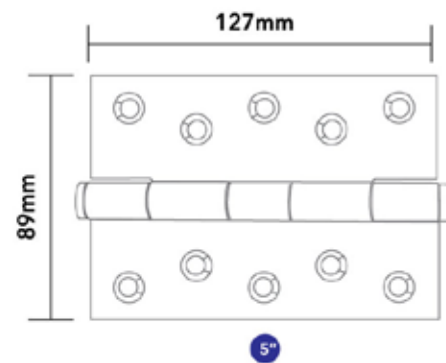
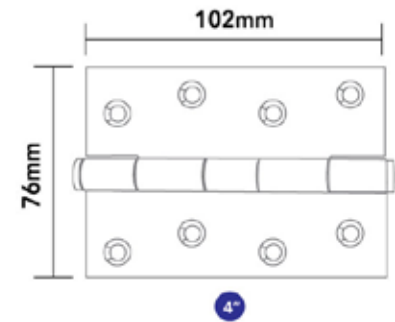
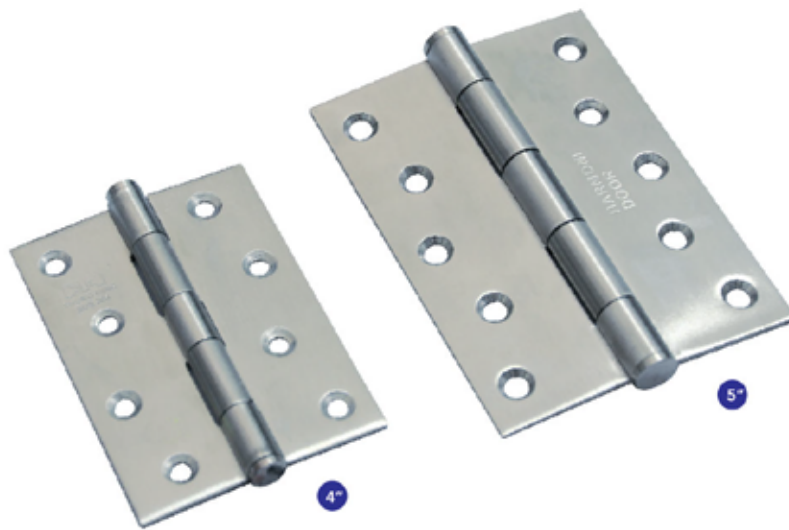

HARMONI HINGES

127MM X 89MM X 2.5MM SUS 304 STAINLESS STEEL HINGES.
(5" X 3.5" X 2.5MM SUS 304 STAINLESS STEEL HINGES)
(4" X 3" X 2.0MM SUS 304 STAINLESS STEEL HINGES)

SPECIFICATIONS:

- 5 Inch Hinge WITHOUT ball bearing
- Usually applied to doors that are of medium-lightweight to medium-heavy weight doors & medium to heavy usage.
- Recommended 3 to 4 nos per door/leaf depending on the door height, usually 3 nos for 2100mm x 900mm standard height & length, anything more than that requires 4 nos per door/leaf.

HARMONIDOOR STAINLESS STEEL MORTISE LOCKSET

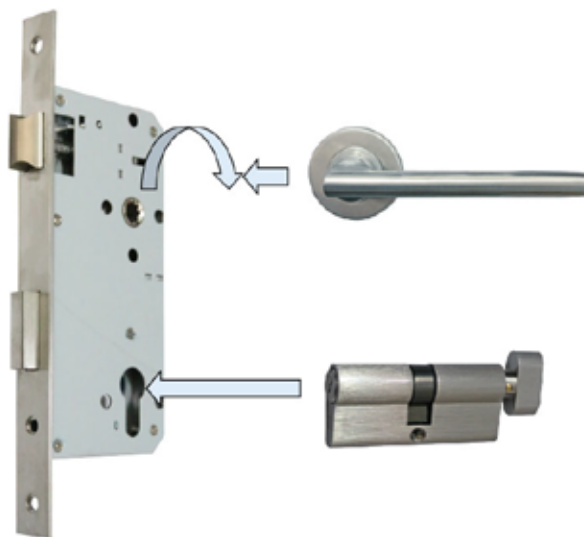

A	FOREND PLATE
B	LATCH BOLT
C	DEAD BOLT
D	SCREW CHANNEL FOR CYLINDER
E	LOCKCASE
F	ACTION-ARM
G	FOLLOWER
H	TURNING DEVICE
I	SPRING

J	BACKSET
K	DISTANCE
L	LOCKCASE WIDTH
M	LOCKCASE HEIGHT
N	FOREND LENGTH
O	FOREND WIDTH
P	LOCKCASE THICKNESS
Q	FOREND THICKNESS

CERTIFICATES & APPROVALS

- STANDARD BS EN 12209:2003
- PASSED in SIRIM QAS INTERNATIONAL Lab.
- Material Brass

SPECIFICATION FOR HARMONIDOOR EURO PROFILE CYLINDER

- Function Double Key @ Single Key & Thumbturn
@ Half Cylinder with Thumbturn @ Half Cylinder with Key

LOCKSET ACCESSORIES

HARMONIDOOR STAINLESS STEEL LEVER HANDLE

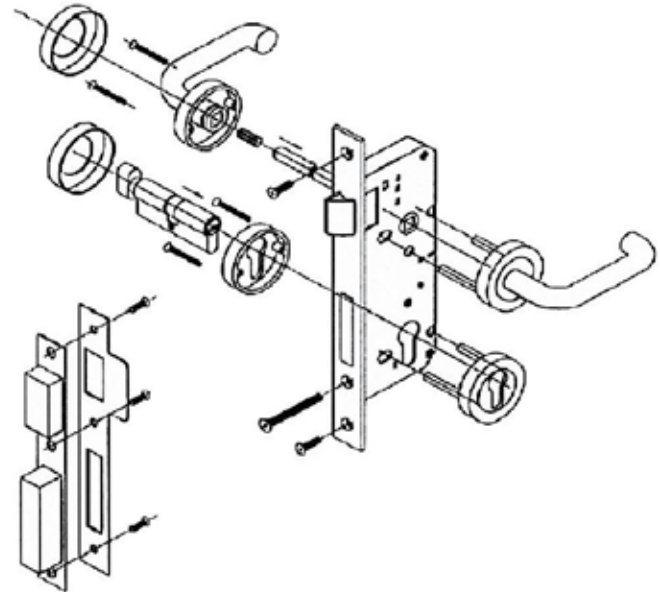
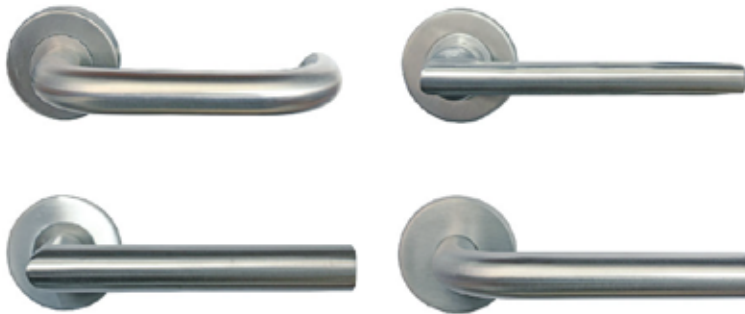

SPECIFICATIONS:

- Stainless Steel SUS304 Lever Handle & Rose.
- Suitable for 72mm or 85mm Centre to Centre Installation Distance.
- Applied To The Left or Right Open Door.

CERTIFICATES & APPROVALS

- STANDARD BS EN 12209:2003
- PASSED in SIRIM QAS INTERNATIONAL Lab.

HARMONIDOOR STAINLESS STEEL DOOR CLOSER



TECHNICAL INFORMATION & FUNCTION		
Model		D523BC @ D536
Backcheck Function		✓
Width of Door (mm) Max.		1500
Width of Door (kg) Max.		150
Max Open Angle		180°
Spring Strength Adjustable		3-6
Closing Speed Adjustment	Speed 1	180° - 15°
	Speed 2	15° - 0°
Applicable Temperature		-30 ~ 40
Weight (kg)		1.56kg
Dimension of Main Body	Length	248
	Width	44.5
	Height	72
Passed Durability Test		500000

CERTIFICATES & APPROVALS

- STANDARD BS EN 1154 :1997
- PASSED 500,000 Cycle in SIRIM QAS INTERNATIONAL Lab.

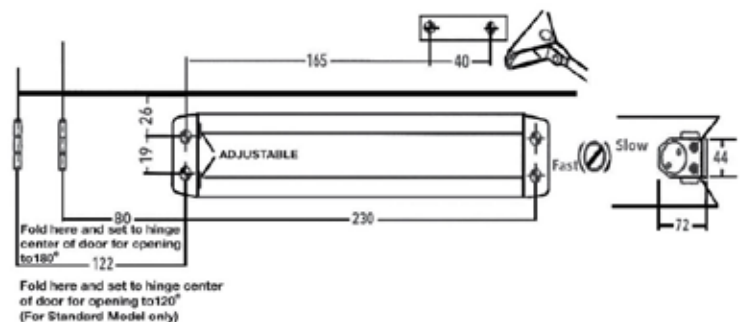

LOCKSET ACCESSORIES

HARMONIDOOR STAINLESS STEEL DOOR SELECTOR

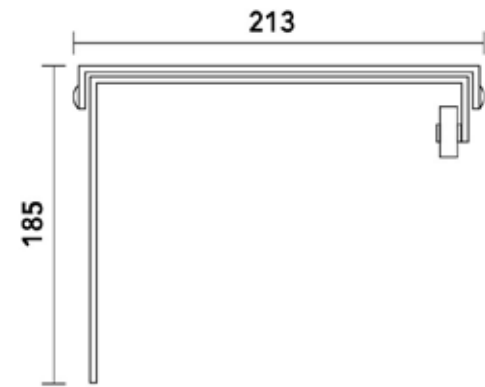

SPECIFICATION

- Stainless Steel SUS304

CERTIFICATES & APPROVALS

- STANDARD BS EN 1158 :1997
- PASSED in SIRIM QAS INTERNATIONAL Lab.

HARMONIDOOR STAINLESS AUTO BOLT

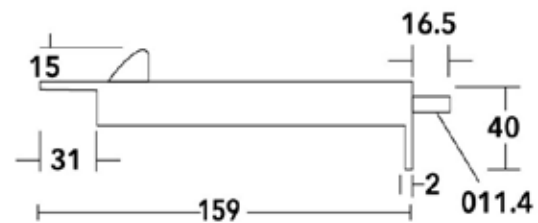

SPECIFICATION

- Stainless Steel SUS304

HARMONIDOOR REBATED PART



SPECIFICATION

Code	A	B	C	Material
Solid Brass Mortise Lock Rebated Part	152	22	9	Brass
	164	23	9	
	169	22.5	9	
	205	22.5	9	
	240	22	9	

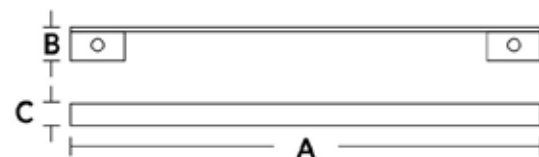

Fire Resistant Door is resisting up to **75** minutes



SINGLE LEAF

PROFIT Fire Door Set meets the requirements of the ms 1073 Part 3 1996 (Amd 1:2003) after the completion of 100,000 cycles.

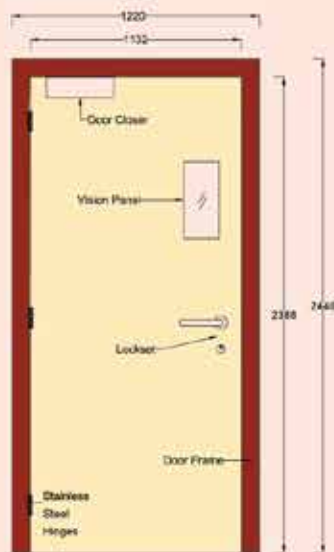

Door Frame Size - One Hour Single Leaf (maximum size 1220mm x 2440mm)

DOUBLE LEAF

PROFIT Fire Door Set meets the requirements of the MS 1073: Part 3: 1996 (Amd. 1.2003) after the completion of 50,000 cycles:

- The Door Set was capable of closing properly, maintaining all clearance between leaf to frame and floor.
- No visible signs of undue wear or damage on any part of the assembly or other defects that could impair its reliability of functioning.



Door Frame Size - One Hour Double Leaf (maximum size 2440mm x 2440mm)

CROSS SECTION OF DOOR LEAF

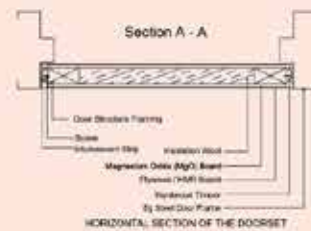

SIRIM TEST



DETAILS OF DOOR FRAME 1 HOUR SINGLE LEAF & 1 HOUR DOUBLE LEAF

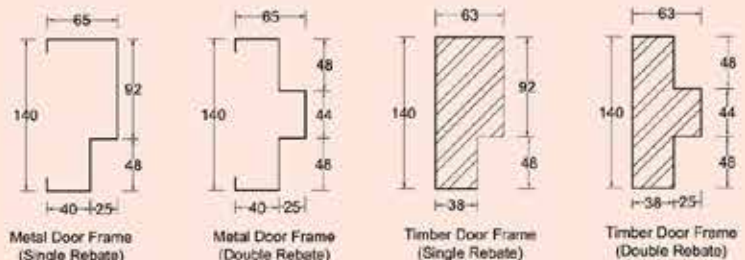

CROSS SECTION OF DOOR LEAF

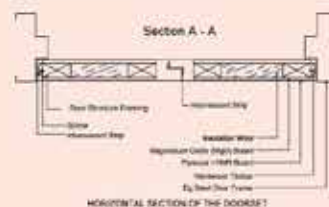

SIRIM TEST



Fire Resistant Door is resisting up to **135** minutes



SINGLE LEAF

PROFIT Fire Door Set meets the requirements of the ms 1073 Part 3 1996 (Amd 1:2003) after the completion of 100,000 cycles.

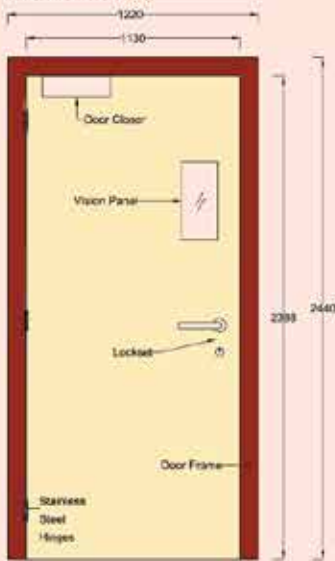

Door Frame Size - Two Hour Single Leaf (maximum size 1220mm x 2440mm)

CROSS SECTION OF DOOR LEAF	DETAILS OF DOOR FRAME	SIRIM TEST
<p>HORIZONTAL SECTION OF THE DOORSET 2 HOUR RATING SINGLE LEAF</p>	<p>Metal Door Frame (Single Rebate) Metal Door Frame (Double Rebate)</p>	

DOUBLE LEAF

PROFIT Fire Door Set meets the requirements of the MS 1073 Part 3: 1996 (Amd: 1:2003) after the completion of 50,000 cycles:

- The Door Set was capable of closing properly, maintaining all clearance between leaf to frame and floor.
- No visible signs of undue wear or damage on any part of the assembly or other defects that could impair its reliability of functioning.



Door Frame Size - Two Hour Double Leaf (maximum size 2440mm x 2440mm)

CROSS SECTION OF DOOR LEAF	DETAILS OF DOOR FRAME	SIRIM TEST
<p>HORIZONTAL SECTION OF THE DOORSET 2 HOUR RATING DOUBLE LEAF</p>	<p>Metal Door Frame (Single Rebate) Metal Door Frame (Double Rebate)</p>	

FIRE RESISTANCE TEST IN ACCORDANCE WITH BS EN 1634-1 2008 (HONG KONG)

RED
Fire and Heat Solutions

RESEARCH ENGINEERING DEVELOPMENT FACILITY COMMERCIALS UNIT
The Good Practice Testing Laboratory
20, Jalan Kesidang 2, Kawasan Industri Uj. Choh,
48202 Seremban, Negeri Sembilan, Malaysia

HS
KUALA
LUMPUR

Page 1 of 27

FIRE RESISTANCE TEST IN ACCORDANCE WITH BS EN 1634-1: 2008
On Fully Insulated Single-acting Equal Double Leaves Composite Steel Doorset

Test Report No.: E16005-1A
Method/Spec No.: Q16C25

Issue Date: 26 September 2015

Testing Location:
RED Engineering Laboratory
CD 134, Lung Kwai Tin, Tuen Mun,
N.T., Hong Kong

Test Specimen:
Seraf Hainam Sdn Bhd
20, Jalan Kesidang 2, Kawasan Industri Uj. Choh,
48202 Seremban, Negeri Sembilan, Malaysia

APPROVED SIGNATURE:  DATE: 26 SEP 2015
R. Li, Yuan Liang, ENACE (HS)

HSK Engineering Services (HK) has conducted the laboratory test in accordance with the RED Engineering Laboratory Accreditation Scheme (Q16C25) for specific laboratory activities as listed in the RED Accreditation of Competence Certificate. The results shown in this test report have been determined by the laboratory in accordance with the terms of accreditation. We accept no responsibility for misquoting or misuse of this report.

T: +852 2627 4822 F: +852 2627 4116 E: info@red.com.hk W: www.red.com.hk

APPENDIX A – Photos and Test Record



Photo 1: The unexposed face of the specimen before the test.

RED
Fire and Heat Solutions

Test Report No.: E16005-1A
Page 14 of 27

Figure 1 – Locations and reference numbers of displacement transducers.
(This figure is not to scale.)

T: +852 2627 4822 F: +852 2627 4116 E: info@red.com.hk W: www.red.com.hk

RED
Fire and Heat Solutions

Test Report No.: E16005-1A
Page 20 of 27

– End of report –

T: +852 2627 4822 F: +852 2627 4116 E: info@red.com.hk W: www.red.com.hk

ACOUSTIC FIRE RATED DOOR

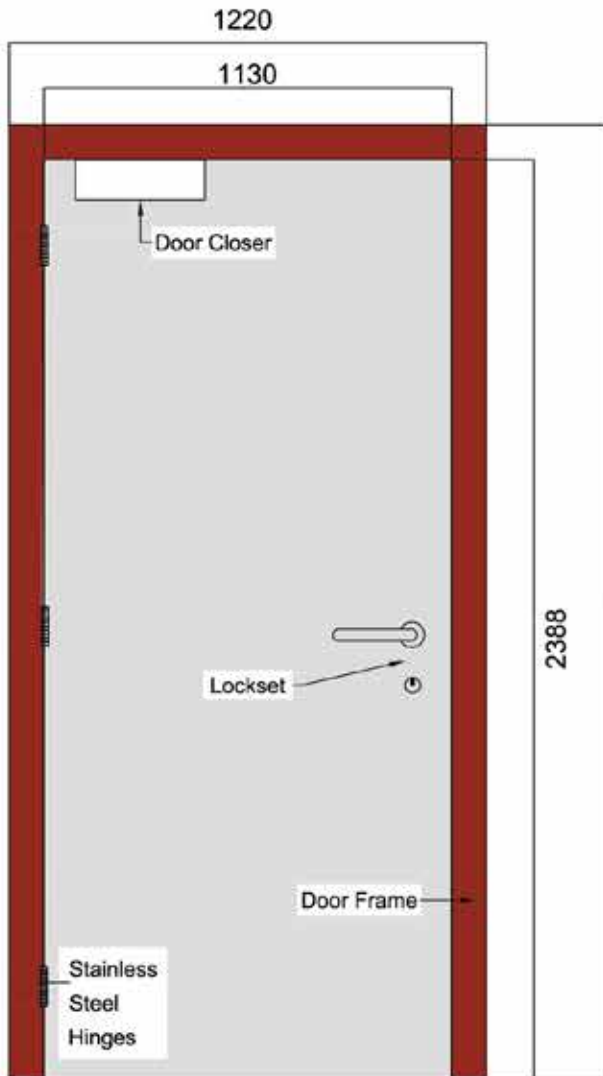

Door Frame Size - One Hour Single Leaf
(Maximum size 1220mm x 2440mm)

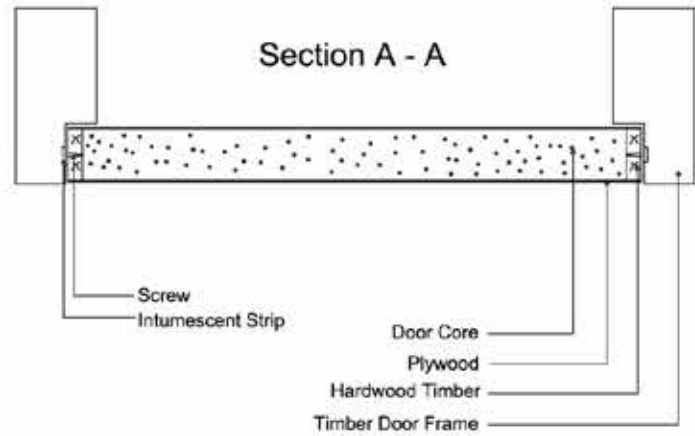

HORIZONTAL SECTION OF THE DOORSET

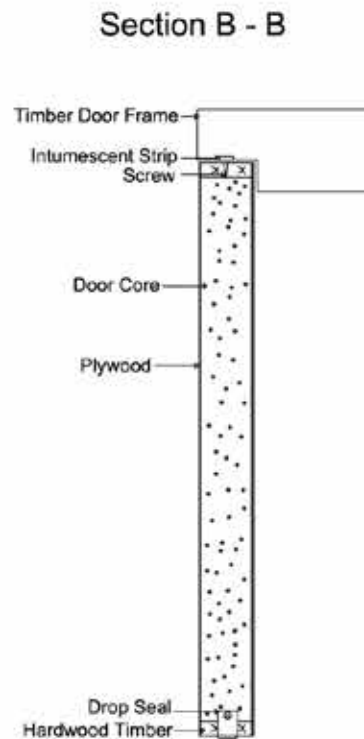

VERTICAL SECTION OF THE DOORSET

PROJECT LIST

THI HARDWARE TRADING SDN BHD (567864-W)

ITEM	LIST OF PROJECT	YEAR
1	98# KEDAI PEJABAT 3 TINGKAT SN23 SCINTEX SENAI 2, JOHOR	2019
2	200# DOUBLE STOREY TERRACE HOUSE - PHASE MDBA2, SCINTEX DURIAN TUNGGAL, MELAKA	2019
3	2 BLOK KONDOMINIUM MEWAH 46 TINGKAT (328 UNITS) DENGAN 4 1/2 TINGKAT TEMPAT LETAK KERETA BAWAH PARAS JALAN PANTAI PRIMA (JALAN 112/H) OFF JALAN KERINCHI	2019
4	158U SHOP LOT AT AUSTIN HEIGHT, JOHOR BHARU	2019
5	PEMBINAAN RUMAH KELUARGA ANGKATAN (RKAT) PELBAGAI JENIS DI KEM TOK JALAI, KELANTAN	2019
6	LOT 5024 - 5028, MUKIM TERIANG DAERAH BERA, PAHANG	2019
7	179U - LOT 28044 (PN 58705), MUKIM BUKIT BATU, DAERAH KUALAJAYA, JOHOR	2019
8	8261 - PANGSAPURI BLOK A & B, LOT 20028, JALAN COCHRANE SEKSYEN 90 (NEAR IKEA) KUALA LUMPUR	2019
9	P157 - APARTMENT SUASANA (PH2&3) AT DAMANSARA DAMAI	2019
10	PPR SUNGAI TIRAM, BT 17 JALAN BASIR, SUNGAI TIRAM JOHOR	2019
11	THE PARK 2 PROJECT (PARCEL F), PUSAT BANDAR JALAN JALIL UTAMA 2, BUKIT JALIL, 57000 KUALA LUMPUR	2019
12	CADANGAN MEMBINA 2 BLOK RUMAH PANGSA KOS SEDERHANA 17 TINGKAT (404 UNIT) DI ATAS LOT 3244 (GM210) DAN LOT 35641 (LOT ASAL 3248 (GM358), MUKIM RASAH DAERAH SEREMBAN, NEGERI SEMBILAN	2019
13	TIARA SENDAYAN PRECINT 3 @ BANDAR SRI SENDAYAN, N.SEMBILAN	2019
14	50 UNITS DSTH & 65 UNITS TOWN HOUSE AT AMPANGAN, SEREMBAN	2019
15	3 STOREY SUPPER LINK HOUSE @ JALAN LAKSAMANA 10, KLANG	2019
16	MONT JADE BUNGALOWS, LOT 5539-5542, MKM SEREMBAN, N.SEMBILAN	2019
17	SEKOLAH BIMBINGAN JALINAN KASIH LORONG HJ HUSSEIN 2, JALAN CHOW KIT K.L	2019
18	KOLEJ POLY-TECH MARA (KPTM), LOT 339325, BANDAR BARU MERU RAYA MK HULU KINTA, DAERAH KINTA, IPOH	2019
19	LOT 3292, JALAN TANJUNG KARANG (LORONG MASTAM), KLANG	2019
20	LOT 4098, JALAN TANJUNG RHU (LORONG HJ HUSSAIN), KLANG	2019
21	LOT 1926-1942 & LOT 2121, MUKIM RIM, DAERAH JASIN MELAKA	2019
22	LOT 4803, PERSIARAN MASJID SULTAN 19E/KS13, KAMPONG TELUK NIPAH 42920 PULAU INDAH	2019
23	AD3B2 - ALAM DAMAI, PERSIARAN DAMAI, ALAM DAMAI CHERAS MUKIM PETALING, K.L	2019
24	LOT 31 -36, SEKSYEN 68, JALAN AMPANG, KUALA LUMPUR	2019
25	RUMAH SELANGORKU, NO 1 (LPT 39829), JALAN NOVA U5/86A, SUBANG BESTARI SEKSYEN U5, 40150 SHAH ALAM, SELANGOR	2019
26	PROJEK PEMBANGUNAN RUMAH KELUARGA ANGKATAN TENTERA DI KEM SEGAMAT, JOHOR	2019
27	CADANGAN MEMBINA 59 UNIT INDUSTRI 1 1/2 ATAS LOT 1650 HINGGA 1710, JALAN CEMPAKA1, KAWASAN PERINDUSTRIAN ANUGERAH SURIA, SG.CHOH, SEKSYEN 20 BANDAR SERENDAH, DAERAH HULU SELANGOR	2019
28	NO.36, JALAN PORTLAND, TASEK INDUSTRIAL ESTATE, 31400 IPOH, PERAK	2019
29	WISMA MONT KIARA, NO.1 JALAN KIRA, MONT KIARA, 50480 K.L	2019
30	LOT 29489 (PT 24684) HINGGA PT 24826 DAN PT 25028, BANDAR BARU NILAI MUKIM SETUL, DAERAH SEREMBAN, N.SEMBILAN	2019
31	PT 4344 - PT 4408 & PT 4483, LOT LAMA 8592, MUKIM HUJUNG PERMATANG DAERAH KUALA SELANGOR	2019
32	LOT 1192 MUKIM TELOK PANGLIMA GARANG	2019
33	MAHKAMAH SYARIAH, KUANTAN PAHANG	2019
34	30 UNITS RUMAH TERES, 3 TINGKAT DIATAS LOT 6283, JALAN BUMI HIJAU KAMPUNG PERMATA, MUKIM RAWANG, DAERAH GOMBAK	2019
35	NO.2 & 4 JALAN BK 1/19, KINRARA INDUSTRIAL PARK, BANDAR KINRARA 47100 PUCHONG, SELANGOR	2019
36	BANDAR TASIK PUTERI, RAWANG (15 TINGKAT)	2019
37	CYBERSOUTH TOWN HOUSE, MUKIM DENGKIL, SEPANG	2019
38	BANDAR SERI IMPIAN - IMPIANA BAYU 3B2, KLUANG, JOHOR	2019
39	CONSTRUCTION OF 103 UNITS TERRACE HOUSES AT ZONE C, TAMAN BUKIT DAHLIA PASIR GUDANG, JOHOR	2019
40	CONSTRUCTION OF 96 UNITS TERRACE HOUSES AT TAMAN MUTIARA GADING BATU PAHAT, JOHOR	2019
41	PLATINUM ARENA OLD KLANG ROAD	2021
42	10 TINGKAT PANGSAPURI 112 UNIT) DI JALAN SELADANG, PENANG (ALMA)	2021
43	KUARTERS PEKERJA DENGKIL, SEPANG (IOI)	2021
44	MIX DEVELOPMENT IN BALUK PAHANG PHASE 3 & SHOP LOT	2021
45	RUMAH SELANGOR KU PUNCAK ALAM	2021
46	TOWN HOUSE AT TAMAN SRI MUDA SHAH ALAM PHASE 1,2,3,4,5,6	2021
47	TERES LAMBAIAN DUA, BANGI	2021
48	PHASE 12, BANDAR RIMBAYU.	2021
49	LOT 491 TNB LEBUH PANTAI BANGSAR	2022
50	EDUMETRO CONDOMINIUM SUBANG JAYA	2022
51	BLOOMSVALE RESIDENCE JALAN KLANG LAMA	2022
52	NEXUS KAJANG MKH	2022
53	PROTON SHOW ROOM & SERVICE CENTER	2022
54	HEMMON HOUSE JALAN IMBI	2022
55	SKY AWANI AIR PANAS	2022
56	DATA CENTER CYBERJAYA	2022
57	HYATT HOTEL, BUKIT JALIL.	2022
58	CORE RESIDENCE, KL.	2022
59	HOSPITAL, PASIR GUDANG	2022
60	308 DSTH, PHASE 14, BANDAR RIMBAYU.	2022
61	YOLO, SUNWAY MENTARI, PJ	2022
62	PHASE 1: 20 SEMI D FACTORY, PHASE 2: 10 SEMI D FACTORY, JALAN KOPORAT 9, KAPAR, KLANG.	2022
63	45 S5TH, JALAN TADUM, KUALA LANGAT.	2022
64	PHASE 12, BANDAR RIMBAYU.	2022
65	KK3, KOK LANAS.	2022
66	KK3, SERIAN, SARAWAK	2022
67	979 TH, 130 SEMI-D, KUANTAN. (PRIYA)	2022
68	65 DSTH, MYRA GARDEN - PH2B	2022
69	295 S5TH, PR1 MA, KUALA LIPIS, PAHANG	2022
70	128 DSTH, MYRA GARDEN - PH1D	2022
71	KONSEP BERPAGAR & BERPENGAWAL 4 BLOK PANGSAPURI, KAWASAN BANDAR VI, MELAKA TENGAH	2022
72	VILLA AVENUE HOUSING DEVELOPMENT	2022
73	RUMAH SELANGORKU PUCHONG LAKE EDGE	2022
74	LOT PT188 PANGSAPURI KOS RENDAH 21 TINGKAT, SENTUL	2022
75	PERUMAHAN 290 UNIT KEDIAMAN DI LOT121, SEKSYEN 94, TAMAN SEPUTEH	2022
76	APARTMENT 4 BLOK 354 UNIT DI BANDAR SEREMBAN, JYC	2022

PROJECT LIST

SERAI HARMONI SDN BHD (1053281-W)

ITEM	LIST OF PROJECT	YEAR
1	CADANGAN KERJA-KERJA PENGUBAHSUAI SATU (1) UNIT BANGUNAN PEJABAT ENAM (6) TINGKAT DAN SEMBILAN BELAS (19) UNIT RUJANG PEJABAT TIGA (3) TINGKAT DI HARUM MAS KOTA KINABALU INDUSTRIAL PARK (KKIP) UNTUK DIJADIKAN POLITEKNIK KOTA KINABALU SABAH FASA II.	2019
2	FASA 1: CADANGAN UNTUK MENDIRIKAN: I) 5 UNIT KEDAI PEJABAT 3 TINGKAT JENIS A II) 5 UNIT KEDAI PEJABAT 3 TINGKAT JENIS B DI ATAS LOT 5735, MUKIM 11, SEBERANG PERAI SELATAN, PULAU PINANG. UNTUK TETUAN: DEMI CANGGIH (PENANG) SDN BHD (NO.SYARIKAT: 1040123-H)	2019
3	CADANGAN TAMBAHAN DAN PINDAAN KEPADA 2 UNIT PEJABAT PAMERAN BERKEMBAR 2-TINGKAT (PLOT 3 DAN 4), DI ATAS LOT BARU 10032 DAN 10033 (SEBAHAGIAN LOT LAMA 186), SEKSYEN 2, JALAN KAMPUNG PAYA, BANDAR BUTTERWORTH, SEBERANG PERAI UTARA, PULAU PINANG.	2019
4	LOT G038, GRD FLOOR, NO.1 PERSIARAN SOUTHKEY 1, SOUTHKEY JOHOR BAHRU 80150	2019
5	LOT 183, JALAN BUKIT BINTANG SEKSYEN 67, KUALA LUMPUR	2019
6	PERMOHONAN PELAN TAMBAHAN DAN UBAHAN BANGUNAN BAGI 1 UNIT KEDAI PEJABAT 3 TINGKAT DI ATAS PTD 57455, (BILL.14 & 14A), JALAN TIMAH SARI, BATU PAHAT, JOHOR	2019
7	DR HOTEL NO.12A, LINTANG SUNGAI TIRAM 5, 11900 BAYAN LEPAS, PENANG MALAYSIA	2019
8	PROJEK BEKALAN ELEKTRIK LUAR BANDAR (BELB) FASA III SISTEM SOLAR HIBRID DI KAMPUNG DAN SEKOLAH - SEKOLAH PENDALAMAN SARAWAK (SK. NANGA BALANG, KAPIT DIVISION	2019
9	CADANGAN MEMBINA & MENYIAPKAN 4 UNIT RUMAH KEDAI 2 TINGKAT DI ATAS LOT PT 8563 & SEBUAH DEWAN SERBAGUNA SERTA KERJA-KERJA BERKAITAN DI KG MENERONG, MUKIM HULLU TERENGGANU, TERENGGANU	2019
10	KAWA LIVING MID VALLEY JOHOR BAHRU 28A, JALAN UDA UTAMA 3/15, TMN BANDAR UDA UTAMA, 81200 JB	2019
11	27 TINGKAT 258 UNITS PANGSAFURI SERVIS BATU 6, OFF JALAN CHERAS K.L	2019
12	TO SUPPLY & DELIVER FULL SET OF 1 HOUR FIRE RATED DOOR.	2019
13	TELEKOM MALAYSIA BERHAD ARAS 14, MENARA TM MELAKA, MITC, 75450 AYER KEROH, MELAKA	2019
14	PROPOSED 1-UNIT 2-STORY DETACHED NURSERY BUILDING ON LOT 3609, BLOCK 5, MIRI CONCESSION LAND DISTRICT JALAN JEE FOH 3, MIRI	2019
15	BARD SDN BHD, LOT 57C, LORONG PERUSAHAAN 5, KULUM INDUSTRIAL ESTATE KULUM 09000 MALAYSIA.	2019
16	CADANGAN MEMBINA DAN MENYIAPKAN 1 UNIT RUMAH KEDAI 2 TINGKAT (BATU) DI ATAS LOT 3445, MUKIM PASIR PUTEH, DAERAH LIMBONGAN, J AJAHAN PASIR PUTEH, KELANTAN.	2019
17	MAXIS KK TOC, CL. 015551283 JALAN BURUNG KELETO, INANAM INDUSTRIAL EASTATE, 88400 KOTA KINABALU, SABAH	2019
18	SUMNER BAY LANG TENGAH ISLAND RESORT SDN BHD GM96, LOT 52, MUKIM PULAU REDANG, PASIR BESAR, KUALA TERENGGANU, TERENGGANU	2019
19	AUSTIN 18, TAMAN MOUNT AUSTIN, JOHOR BAHRU	2019
20	LAGUNA HEIGHTS CONDO, JALAN SRI LAGUNA, TAMAN LAGUNA JOHOR BAHRU	2019
21	47 SHOP OFFICE AT TAMAN PUCHONG UTAMA	2019
22	6 UNITS & 4 UNITS PERINDUSTRIAN BERKEMBAR 3 TINGKAT (86' X 160') DIATAS LOT 2297, (NO HAK MILIK : GRN 48729), MUKIM KAJANG, DAERAH HULLU LANGAT SELANGOR D.R	2019
23	LOT 11749, SHAMELIN STAR, JALAN CHERAS K.L	2019
24	MRT DEPOT BUS 994/998, JALAN SUBANG, KG BARU SG BULOH	2019
25	LOT 48623, JALAN MAMTAP 25/126, SEKSYEN 25 SHAH ALAM	2019
26	SENTROVUE, PUNCAK ALAM	2019
27	M/S DFZ TRADING SDN BHD WISMA ATLAN 8 PERSIARAN KAMPUNG JAWA, BAYAN LEPAS 11900, PENANG.	2019
28	PELAN LULUSAN UNTUK SOKONGAN SUIL PERAKUAN BOMBA BAGI CADANGAN PELAN MENAIK TARAF SISTEM PENCEGAH KEBAKARAN DI KILANG SEDIADA NO.7, ([LOT 6015] JALAN KUKUH, KAWASAN PERINDUSTRIAN TAMPOI, 80350 JOHOR BAHRU, JOHOR	2019
29	CADANGAN PINDAAN, TAMBAHAN DAN TUKARGUNA 1 BLOK BANGUNAN 5 TINGKAT KEPADA HOTEL JIMAT (44 BILIK) (PREMIS NO.140, 140A, 140B, 140C, 140D, 140E, & 140F), JALAN GURDWARA DI ATAS LOT 781, SEK. 11W, BANDAR GEORGETOWN, DTL, PULAU PINANG	2019
30	CADANGAN MEMBINA SEBUAH PEMBANGUNAN YANG MENGANDUNGI: I) 1 UNIT KILANG 1 TINGKAT II) PEJABAT 3 TINGKAT III) 1 UNIT PONDOK PENGAWAL IV) 1 UNIT KEBUK SAMPAH	2019
31	SUMNER BAY LANG TENGAH ISLAND RESORT SDN BHD GM96, LOT 52, MUKIM PULAU REDANG, PASIR BESAR, KUALA TERENGGANU, TERENGGANU	2019
32	CADANGAN MENDIRIKAN KILANG MEMPROSES ITIK YANG MENGANDUNGI 1 UNIT KILANG 1 TINGKAT DI ATAS SEBAHAGIAN PT12854, BANDAR SRI SENDAYAN, DAERAH SEREMBAN, NEGERI SEMBILAN DARUL KHUSUS UNTUK TETUAN XOOON HUP POULTRY FARMING SDN BHD	2019
33	SUMNER BAY LANG TENGAH ISLAND RESORT SDN BHD	2020
34	COURTYARD BY MARRIOTT KL	2020
35	KEMPINSKI HOTEL 8 CONLAY KL	2020
36	EATON RESIDENCE JALAN KIA PENG	2020
37	SKYLUXE RESIDENSI BUKIT JALIL	2020
38	FOREST CITY JOHOR	2020
39	THE ESTATE RESIDENCE BANGSAR SOUTH	2020
40	BSP 21 RESIDENCE SAUJANA PUTRA	2020
41	TSLAW TOWER JALAN KEMUNING, IMBI	2020
42	OPERO HOTEL SOUTH KEY JOHOR BAHRU	2020
43	SUNWAY HOTEL BIG BOX JOHOR ISKANDAR	2020
44	HOTEL SKY SUITE MIDHILL GENTING HIGHLAND	2020
45	TROPICANA HEIGHT KAJANG 2	2021
46	AMBER RESIDENCE KOTA KEMUNING	2021
47	ADELIA RESIDENCE BANGI AVENUE	2021
48	RUMAH SELANGOR KU PUNCAK ALAM	2021
49	REFURBISHMENT FOR NORTH TOWER (SUBANG JAYA MEDICAL CENTER)	2021
50	RESIDENSI AMAN BUKIT JALIL	2022
51	LOT 491 TNB LEBUH PANTAI BANGSAR	2022
52	MAHSA HOSPITAL, BANDAR SAUJANA	2022
53	ISEC PENANG	2022
54	ROYALE RENCANA BLOCK B LEVEL 12-13 UPPER FLOOR	2022
55	PHASE 3 FIRE RATED DOOR REPLACEMENT FOR SOUTH TOWER, NORTH TOWER & OPC AT (SJM)	2022
56	PROTON SHOW ROOM & SERVICE CENTER	2022
57	HEMMON HOUSE JALAN IMBI	2022
58	241 UNIT APARTMENT THE ATRIUM AMPANG HILIR	2022
59	DATA CENTER CYBERJAYA	2022
60	PUTRAJAYA BMD3 MIX DEVELOPMENT	2022
61	HOSPITAL, JENGA, PAHANG	2022
62	PHASE 1: 20 SEMI D FACTORY, PHASE 2: 10 SEMI D FACTORY, JALAN KOPORAT 9, KAPAR, KLANG.	2022
63	45 SSTH, JALAN TADUM, KUALA LANGAT.	2022
64	BOUTIQUE HOTEL, IPOH	2022
65	AQNIA, PPAM, SETAPAK.	2022
66	APARTMENT SELANGORKU (PLOT C), PUCHONG INTAN	2022
67	KONSEP BERPAGAR & BERPENGAWAL 4 BLOK PANGSAFURI, KAWASAN BANDAR VI, MELAKA TENGAH	2022
68	VILLA AVENUE HOUSING DEVELOPMENT	2022
69	APARTMENT 4 BLOK 354 UNIT DI BANDAR SEREMBAN, JYC	2022